

**INDEX**

SHEET NO.	SUBJECT
1	Drawing Index
2	Single Signal Arm Pole Elevation, Dimensions, and Base Plate Weld Detail
3	Signal Arm Dimensions & Details
4	Signal Arm Pole Base Plate, Bottom Splice Plates, and Pole Top Cover Details
5	Signal Arm Connection Details
6	Handhole Details
7	Placement of Signals and Signs, Loading for Arm of 35' or Less
8	Placement of Signals and Signs, Loading for Arm of Greater Than 35' to 60'
9	Combination Pole Elevation, Dimensions, and Base Plate Weld Detail
10	Combination Arm Dimensions & Details
11	Combination Arm Connection Details
12	Combination Pole Splice Details for Arms 35' or Less
13	Combination Pole Splice Details for Arm of Greater Than 35' to 60'
14	Combination Arm Loading for Arm of 35' or Less
15	Combination Arm Loading for Arm of Greater Than 35' to 60'
16	Drilled Shaft Foundation Type A for Arm of 35' or Less
17	Drilled Shaft Foundation Type B for Arm of Greater Than 35' to 60'
18	Spread Footing Foundation Type C for Arm of 35' or Less
19	Spread Footing Foundation Type D for Arm of Greater Than 35' to 60'

INDIANA DEPARTMENT OF TRANSPORTATION

TRAFFIC SIGNAL CANTILEVER STRUCTURE  
DRAWING INDEX

SEPTEMBER 2013

STANDARD DRAWING NO. E 805-TSCS-01

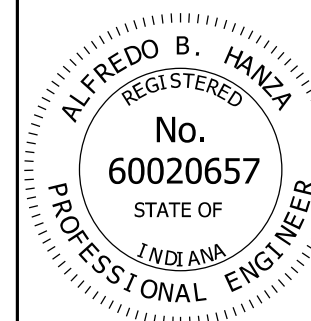

*/s/ Alfredo B. Hanza*                      02/05/13

DESIGN STANDARDS ENGINEER                      DATE

*/s/ Mark A. Miller*                      03/27/13

CHIEF ENGINEER                      DATE

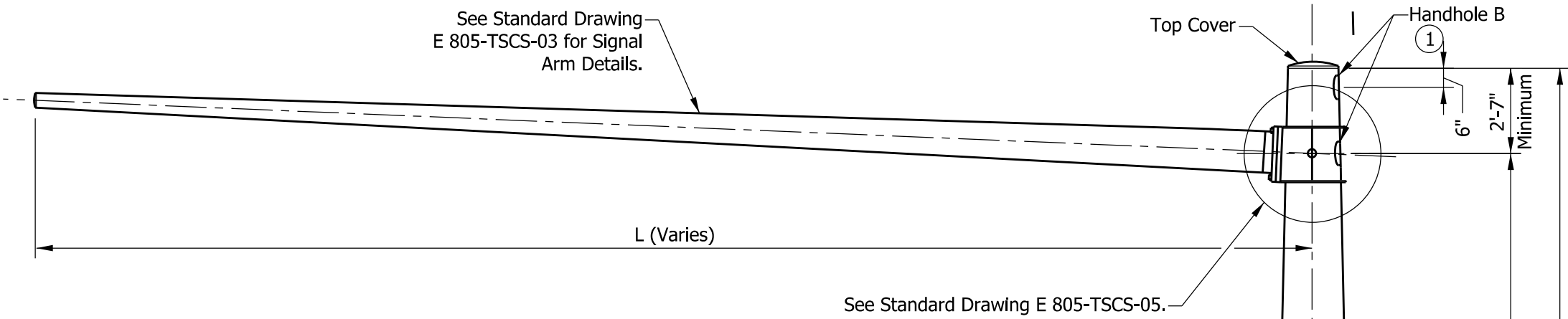

**NOTES:**

- ① See Standard Drawing E 805-TSCS-06 for handhole details.
- 2. See Standard Drawing E 805-SGGR-01 to -03 for grounding details.
- ③ Use continuous backing ring, 5/16" x 2" minimum. Tack weld only in root area of final weld.

POLE DIMENSIONS		
CANTILEVER ARM LENGTH L	SECTION 1	
	BASE DIAMETER	WALL THICKNESS
15' to 35'	17"	5/16"
>35' to 60'	24"	5/16"

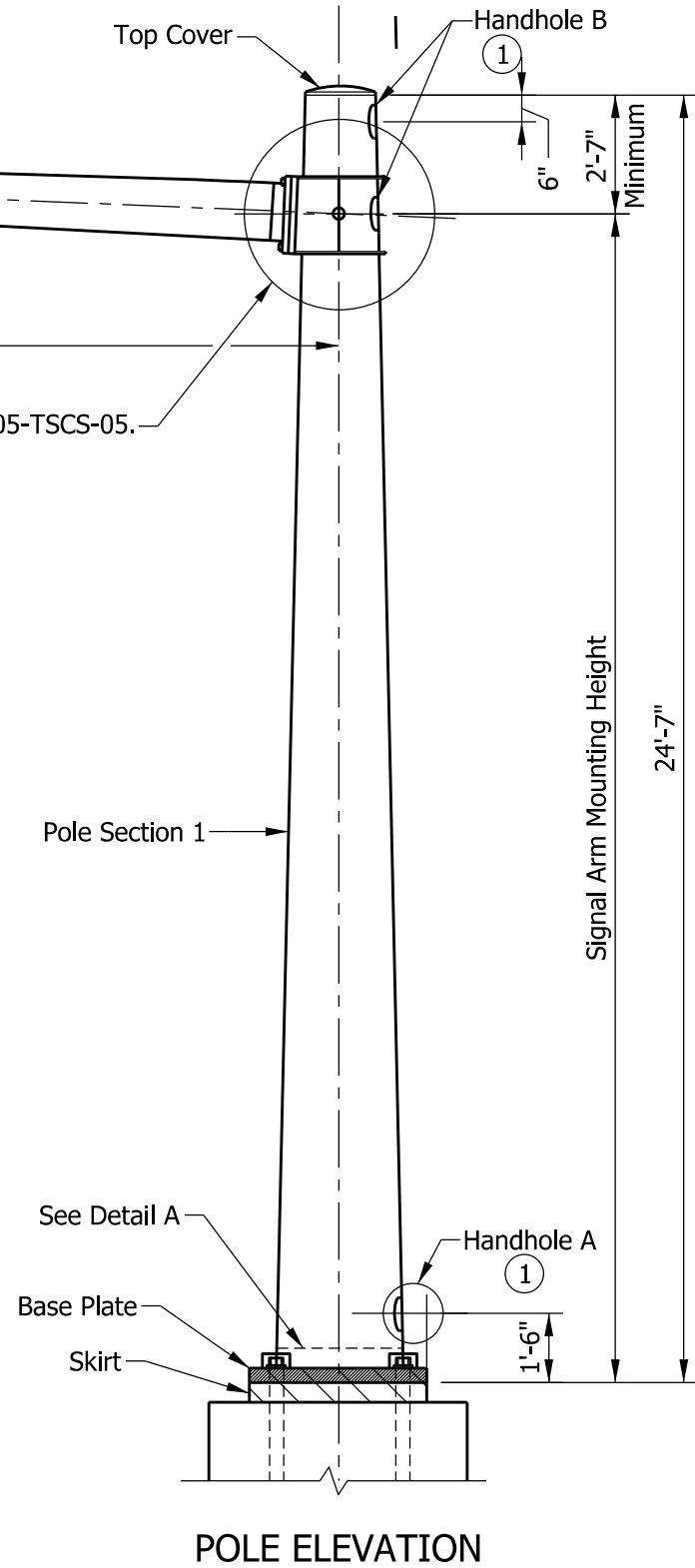
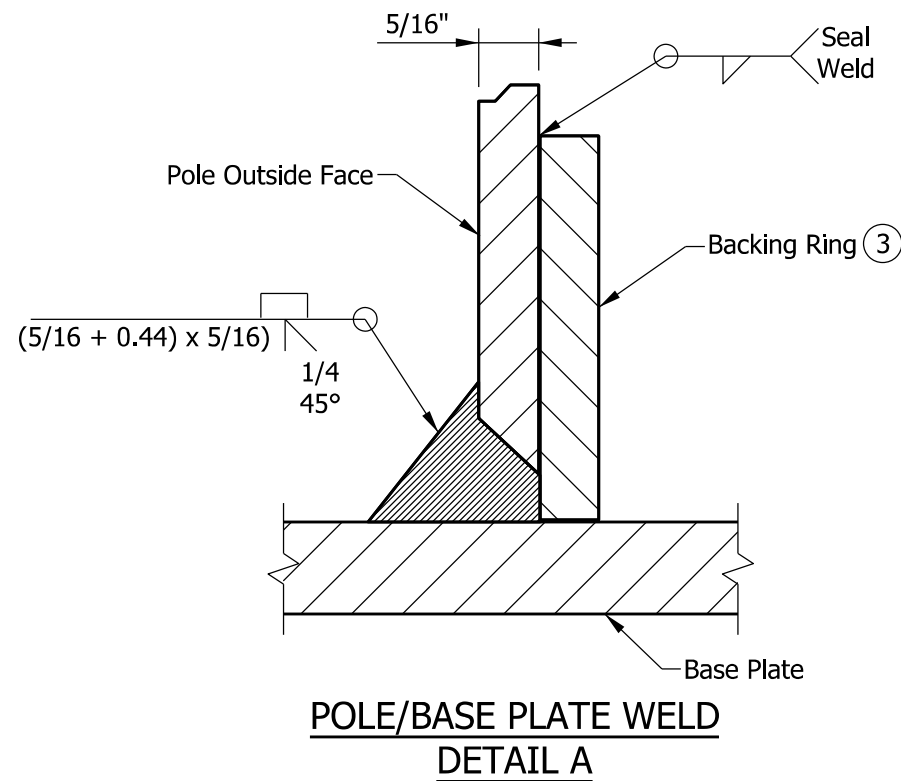

<b>INDIANA DEPARTMENT OF TRANSPORTATION</b>									
<b>TRAFFIC SIGNAL CANTILEVER STRUCTURE SINGLE SIGNAL ARM POLE ELEVATION, DIMENSIONS, AND BASE PLATE WELD DETAIL SEPTEMBER 2018</b>									
<b>STANDARD DRAWING NO. E 805-TSCS-02</b>									
	<table style="width: 100%; border-collapse: collapse;"> <tr> <td style="text-align: center; border-bottom: 1px solid black;"><i>/s/ David H. Boruff</i></td> <td style="text-align: center; border-bottom: 1px solid black;">03/12/18</td> </tr> <tr> <td style="text-align: center; font-size: small;">DESIGN STANDARDS ENGINEER</td> <td style="text-align: center; font-size: small;">DATE</td> </tr> <tr> <td style="text-align: center; border-bottom: 1px solid black;"><i>/s/ John Leckie</i></td> <td style="text-align: center; border-bottom: 1px solid black;">05/03/18</td> </tr> <tr> <td style="text-align: center; font-size: small;">CHIEF ENGINEER</td> <td style="text-align: center; font-size: small;">DATE</td> </tr> </table>	<i>/s/ David H. Boruff</i>	03/12/18	DESIGN STANDARDS ENGINEER	DATE	<i>/s/ John Leckie</i>	05/03/18	CHIEF ENGINEER	DATE
<i>/s/ David H. Boruff</i>	03/12/18								
DESIGN STANDARDS ENGINEER	DATE								
<i>/s/ John Leckie</i>	05/03/18								
CHIEF ENGINEER	DATE								

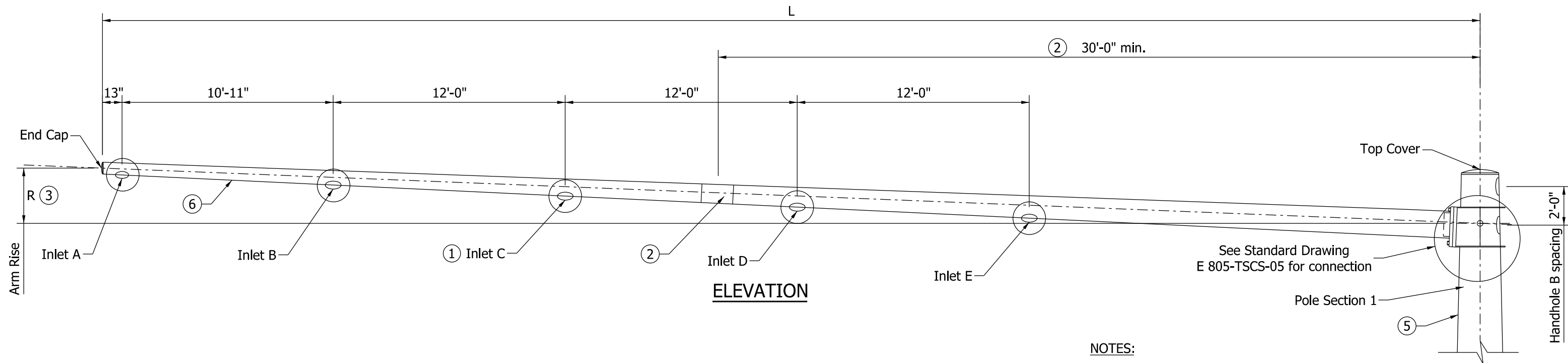

See Standard Drawing E 805-TSCS-05 for connection

**NOTES:**

- ① Number of cable inlets depends on arm L (See Arm Dimensions Table). The inlet diameter shall be 1 3/4" with rubber grommet (Typ.)
- ② Optional splice can be used for arm length of greater than 40'. Field assembly shall achieve a snug tight joint, with minimum overlap not less than 1.5 times the inside dimension of the end section.
- ③ Arm rise R is measured in the undeflected position without vertical loads on the arm.
4. See Standard Drawings E 805-TSCS-07 and -08 for placement of signal and signs for each arm length.
- ⑤ If seam welds are used, the weld location for the arms shall be along the bottom, and on the side of pole as shown.

End section extension with wall thickness 3/16" min. and with drilled hole for 5/8" bolt

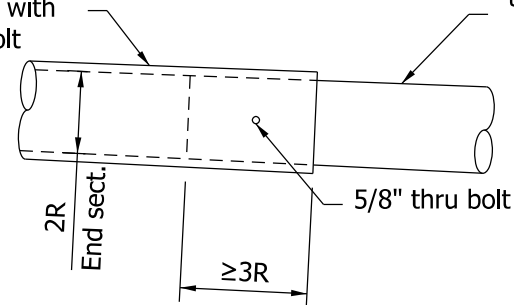

② **OPTIONAL ARM SPLICE DETAIL**

Base section with wall thickness 5/16" and field drilled hole for 5/8" bolt with curved washer and lock nut

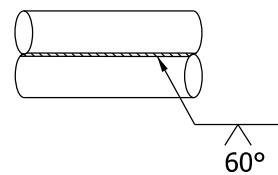

⑤ **TYPICAL SEAM WELD**

ARM DIMENSIONS TABLE				
L (ft.)	ARM DIAMETER AT POLE	ARM WALL THICKNESS (in.)	R (in.)	CABLE INLETS
15	8"	5/16"	7 1/2"	A, B
20	10"	5/16"	10"	A, B
25	11"	5/16"	1'-0 1/2"	A, B
30	13"	5/16"	1'-3"	A, B
35	14"	5/16"	1'-5 1/2"	A, B, C
40	15"	5/16"	1'-8"	A, B, C
45	17"	5/16"	1'-10 1/2"	A, B, C
50	19"	5/16"	2'-1"	A, B, C, D
55	20"	5/16"	2'-3 1/2"	A, B, C, D
60	21"	5/16"	2'-6"	A, B, C, D, E

<b>INDIANA DEPARTMENT OF TRANSPORTATION</b>									
<b>TRAFFIC SIGNAL CANTILEVER STRUCTURE SIGNAL ARM DIMENSIONS &amp; DETAILS</b>									
<b>SEPTEMBER 2013</b>									
<b>STANDARD DRAWING NO.</b>	<b>E 805-TSCS-03</b>								
	<table style="width: 100%; border-collapse: collapse;"> <tr> <td style="width: 80%; border-bottom: 1px solid black;">/s/ <i>Alfredo B. Hanza</i></td> <td style="width: 20%; border-bottom: 1px solid black;">02/05/13</td> </tr> <tr> <td style="font-size: small;">DESIGN STANDARDS ENGINEER</td> <td style="font-size: small;">DATE</td> </tr> <tr> <td style="border-bottom: 1px solid black;">/s/ <i>Mark A. Miller</i></td> <td style="border-bottom: 1px solid black;">03/27/13</td> </tr> <tr> <td style="font-size: small;">CHIEF ENGINEER</td> <td style="font-size: small;">DATE</td> </tr> </table>	/s/ <i>Alfredo B. Hanza</i>	02/05/13	DESIGN STANDARDS ENGINEER	DATE	/s/ <i>Mark A. Miller</i>	03/27/13	CHIEF ENGINEER	DATE
/s/ <i>Alfredo B. Hanza</i>	02/05/13								
DESIGN STANDARDS ENGINEER	DATE								
/s/ <i>Mark A. Miller</i>	03/27/13								
CHIEF ENGINEER	DATE								

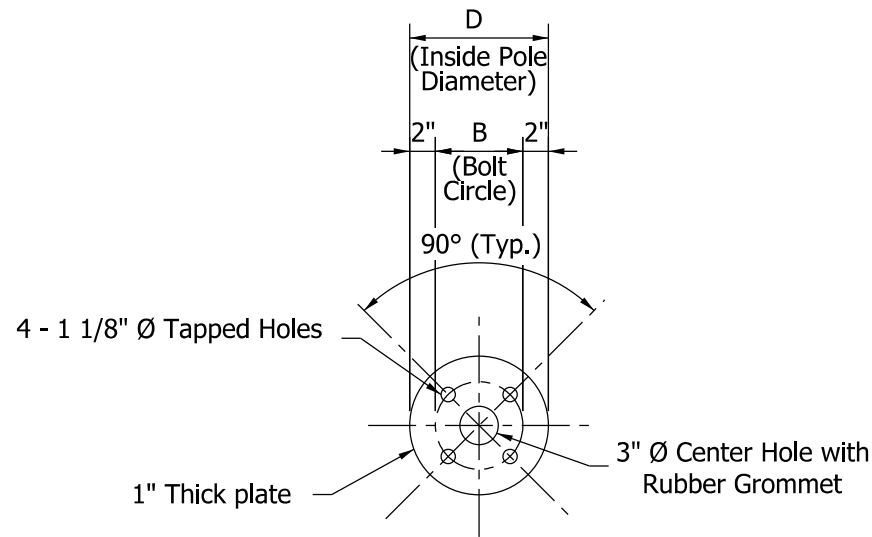

① **BOTTOM SPLICE PLATE**  
(For Cantilever Arm Length of 35' or Less)

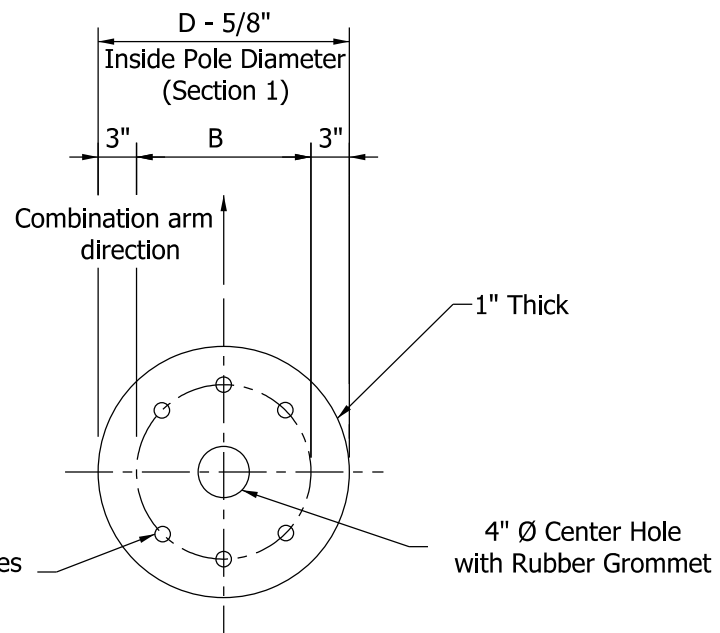

① **BOTTOM SPLICE PLATE**  
(For Cantilever Arm Length Greater Than 35' to 60')

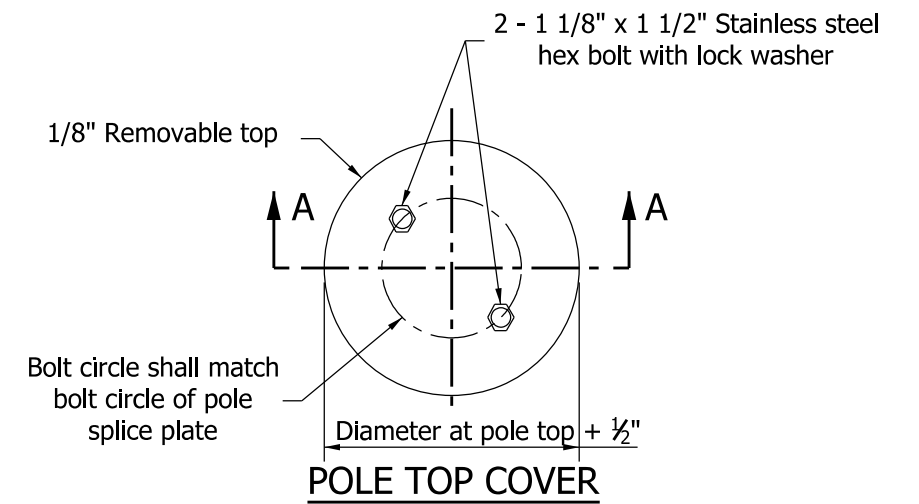

**POLE TOP COVER**

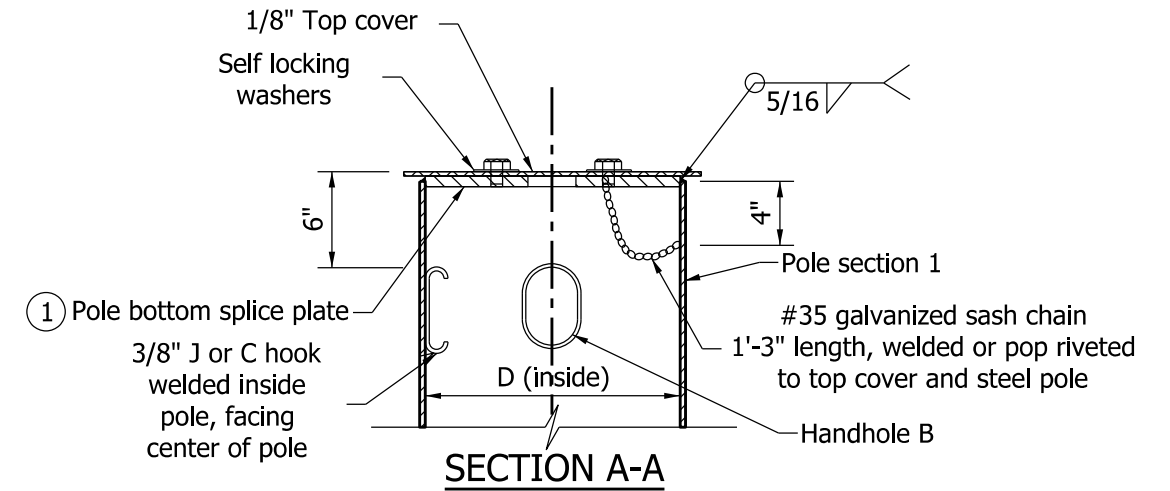

**SECTION A-A**

- ① Pole bottom splice plate  
3/8" J or C hook welded inside pole, facing center of pole
- #35 galvanized sash chain  
1'-3" length, welded or pop riveted to top cover and steel pole
- Handhole B

**NOTES:**

- See Standard Drawings E 805-TSCS-12 and -13 for bottom splice details.
- Bolt circle shall allow clearance for the plate washer. Cutting or trimming the washer will not be allowed.

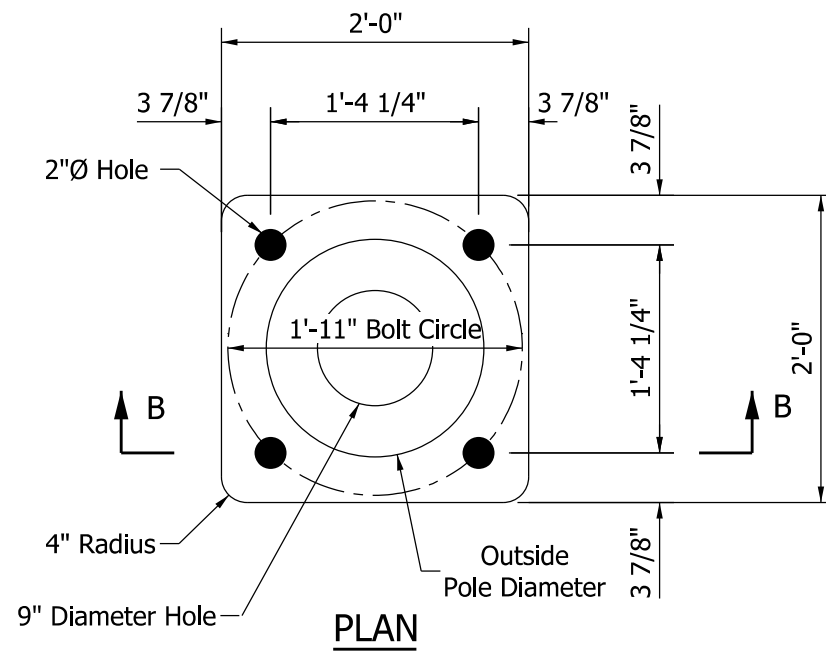

**PLAN**

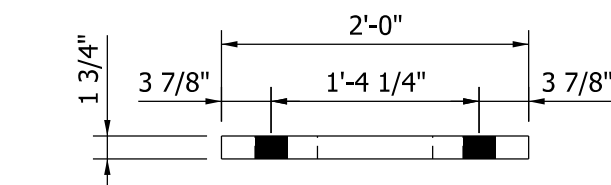

**SECTION B-B**  
**BASE PLATE A**

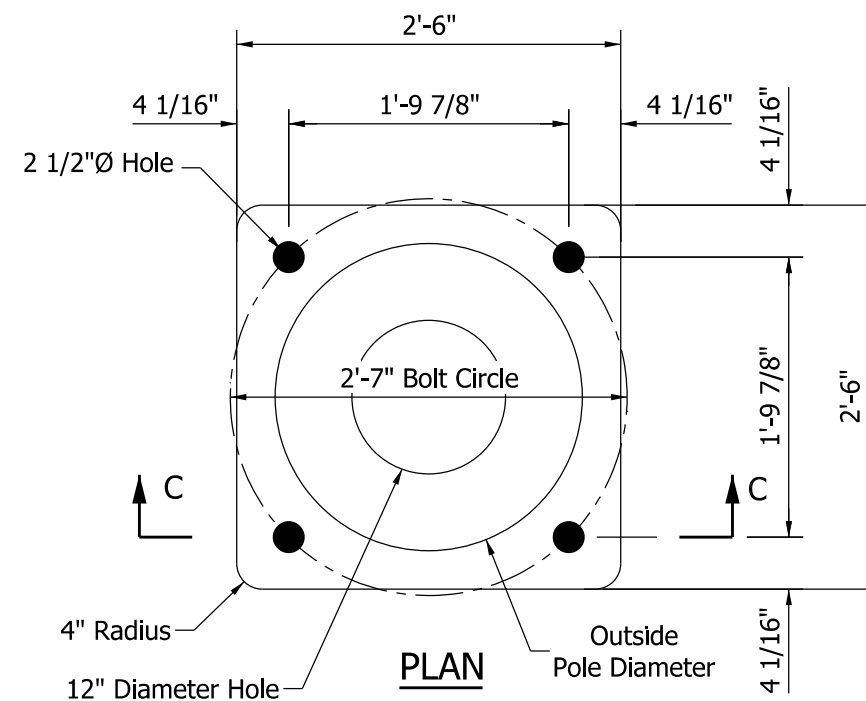

**PLAN**

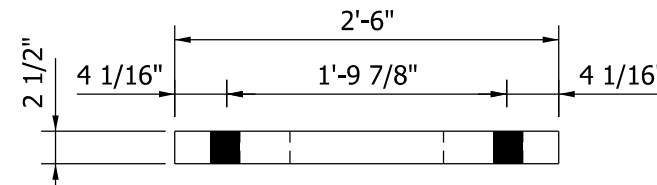

**SECTION C-C**  
**BASE PLATE B**

INDIANA DEPARTMENT OF TRANSPORTATION

TRAFFIC SIGNAL CANTILEVER STRUCTURE  
SIGNAL ARM POLE BASE PLATE, BOTTOM  
SPLICE PLATES, AND POLE TOP COVER DETAILS

SEPTEMBER 2013

STANDARD DRAWING NO. E 805-TSCS-04

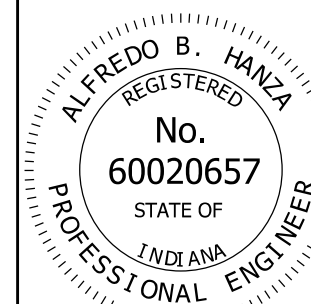

/s/ Alfredo B. Hanza 03/26/13

DESIGN STANDARDS ENGINEER DATE

/s/ Mark A. Miller 03/27/13

CHIEF ENGINEER DATE

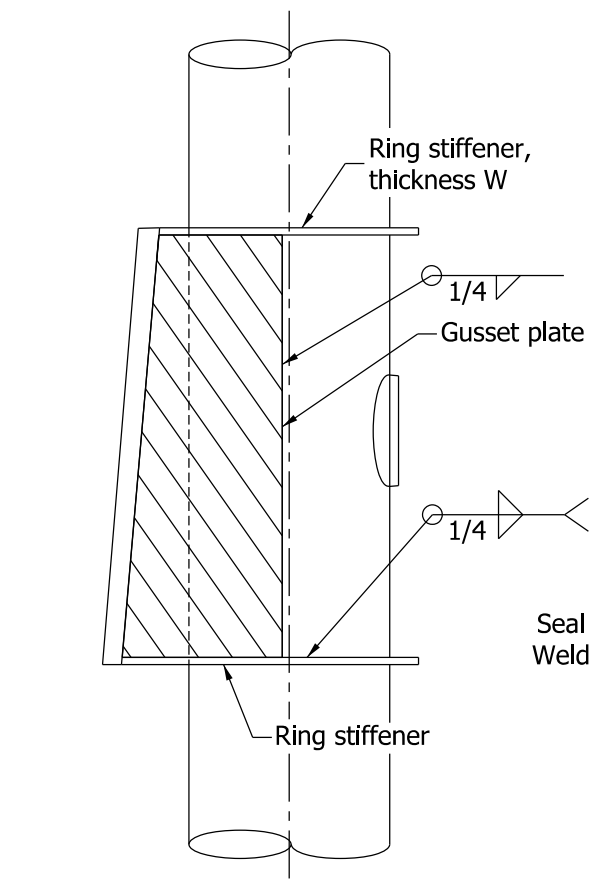

**ELEVATION OF GUSSET PLATE**

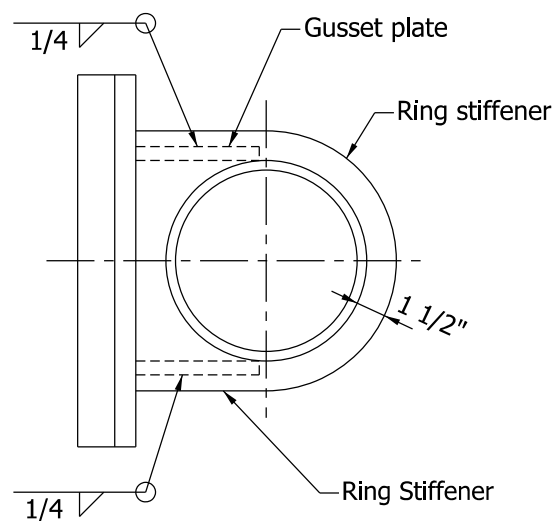

**TOP OF GUSSET PLATE**

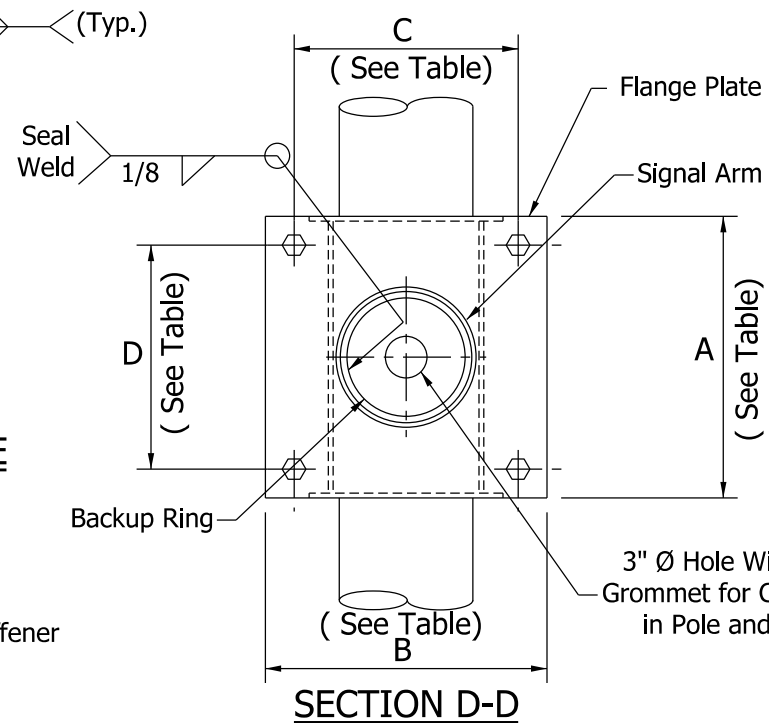

**SECTION D-D**

**SIGNAL ARM CONNECTION DETAIL**

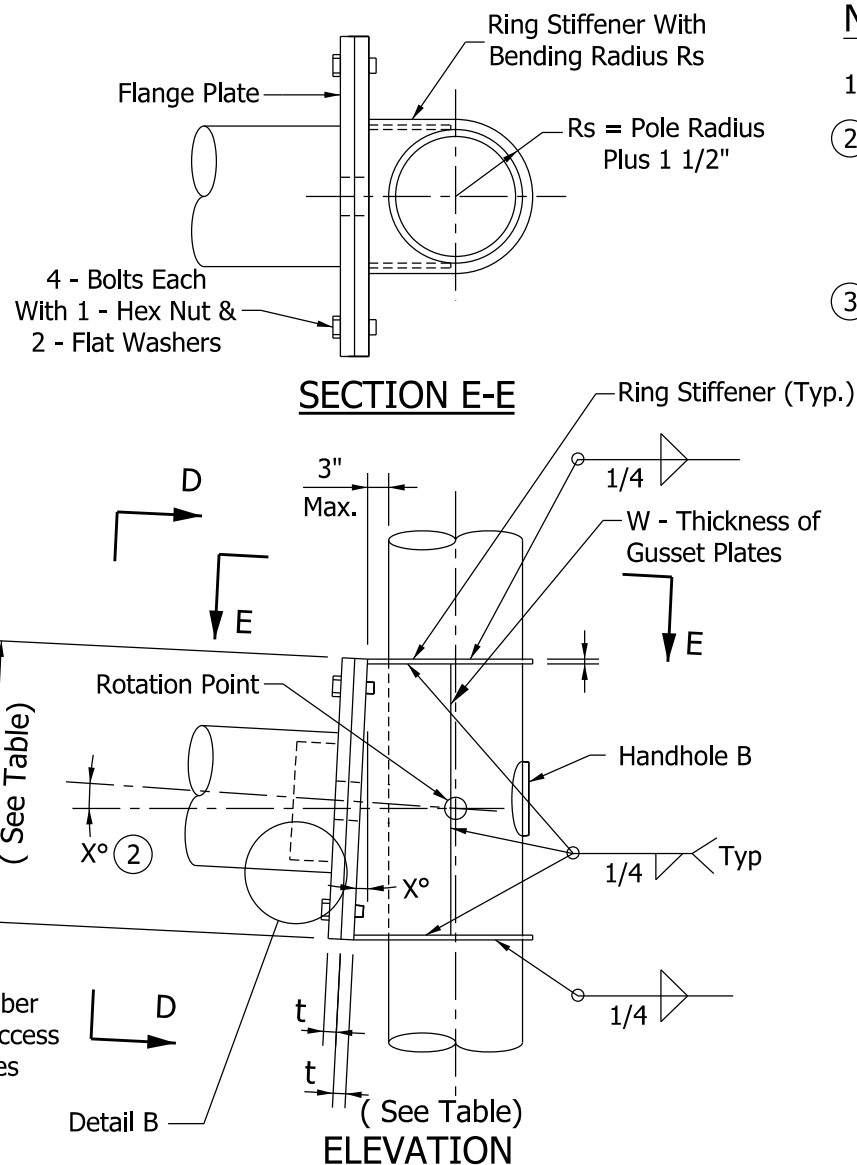

**SECTION E-E**

**ELEVATION**

**NOTES:**

1. See Standard Drawing E 805-TSCS-06 for Handhole B details.
2. The required signal arm rise shall be built into the gusset plate at the angle X. The angle X is described as arc tan R/L, where R is the arm rise and L is the arm length. Both R and L vary and are listed in the Arm Dimension Table on Standard Drawing E 805-TSCS-03.
3. Use continuous backing ring, 5/16" x 2" minimum. Tack weld only in root area of final weld.

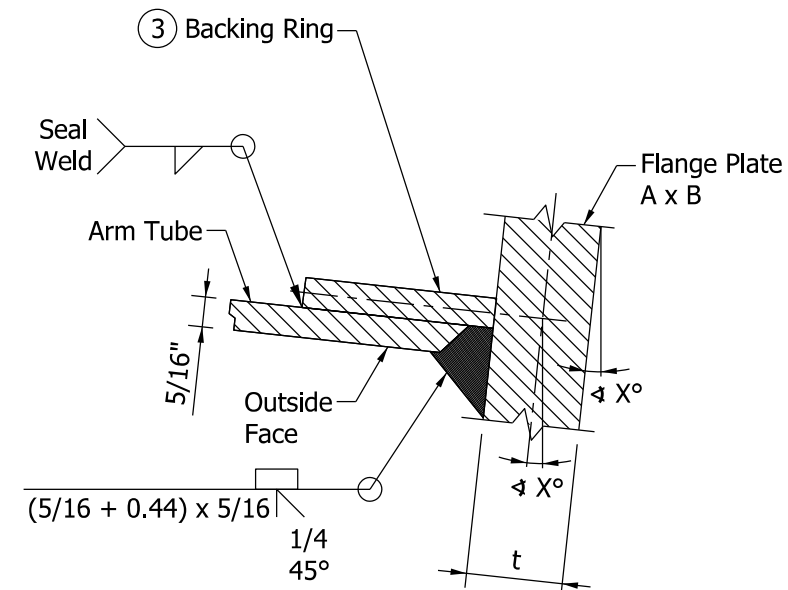

**DETAIL B - ARM WELD**

PLATES AND BOLTS FOR SIGNAL SINGLE ARM CANTILEVER					
ARM LENGTH	FLANGE PLATE A x B	BOLT PATTERN C x D	RING STIFFNER GUSSET PLATE W	FLANGE PLATE THICKNESS t	BOLT
15' to 35'	22" x 22"	17 1/2" x 17 1/2"	3/8"	1 1/2"	1 1/8" - 7 UNC x 4 1/4" Long
>35' to 60'	33" x 33"	27 1/2" x 27 1/2"	1/2"	1 3/4"	1 1/2" - 6 UNC x 6 1/4" Long

INDIANA DEPARTMENT OF TRANSPORTATION

TRAFFIC SIGNAL CANTILEVER STRUCTURE  
SIGNAL ARM CONNECTION DETAILS

SEPTEMBER 2014

STANDARD DRAWING NO. E 805-TSCS-05

	/s/ <i>Alfredo B. Hanza</i> 12/02/13 DESIGN STANDARDS ENGINEER      DATE
	/s/ <i>Mark A. Miller</i> 12/05/13 CHIEF ENGINEER      DATE

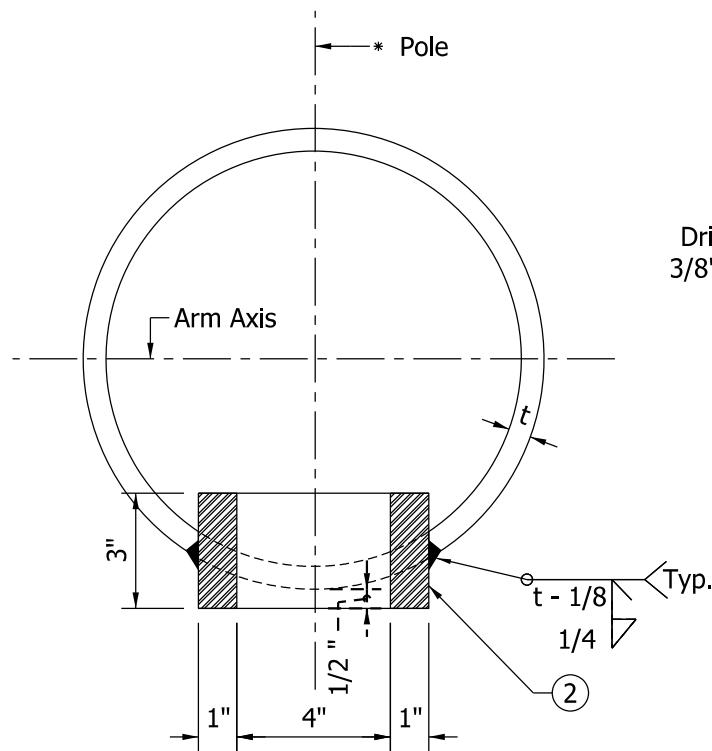

**HANDHOLE B  
SECTION ACROSS POLE**

Drill and tap for 2 screws,  
3/8" - 20 Chase thread after  
galvanizing

1"x 3" flat  
bar frame

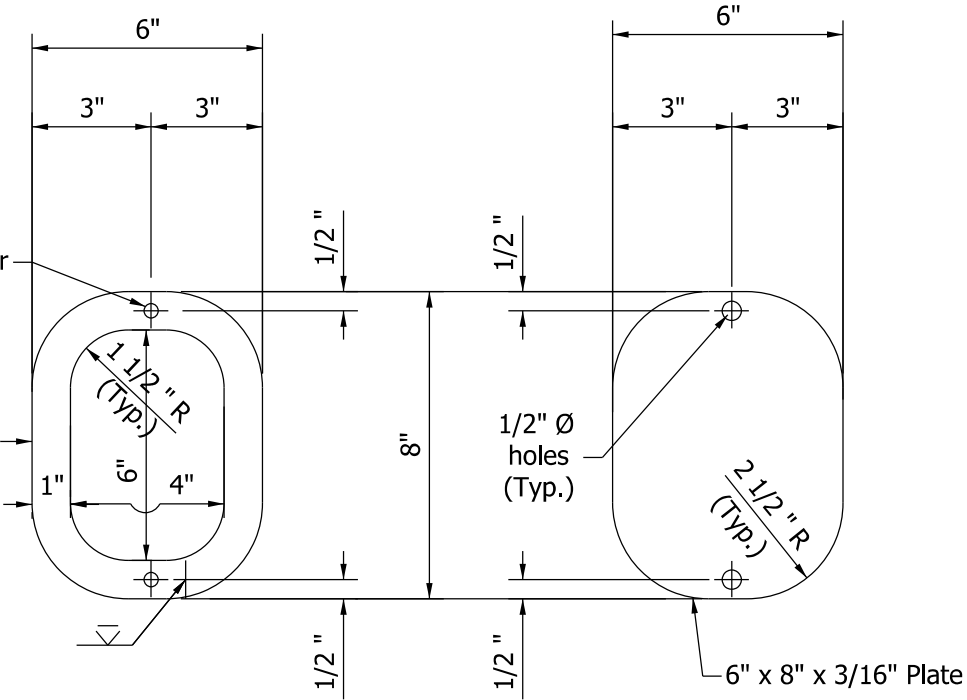

**FRAME DETAIL**

**COVER**

**HANDHOLE B**

**NOTES:**

- 1 Handhole A shall be used at the base of the pole. Handhole B shall be used at all other locations.
- ② In lieu of fabricated handhole frame as shown, frame may be cut from 3" plate with rolling direction vertical.
- 3 See Standard Drawings E 805-TSCS-02 and -09 for handhole locations.

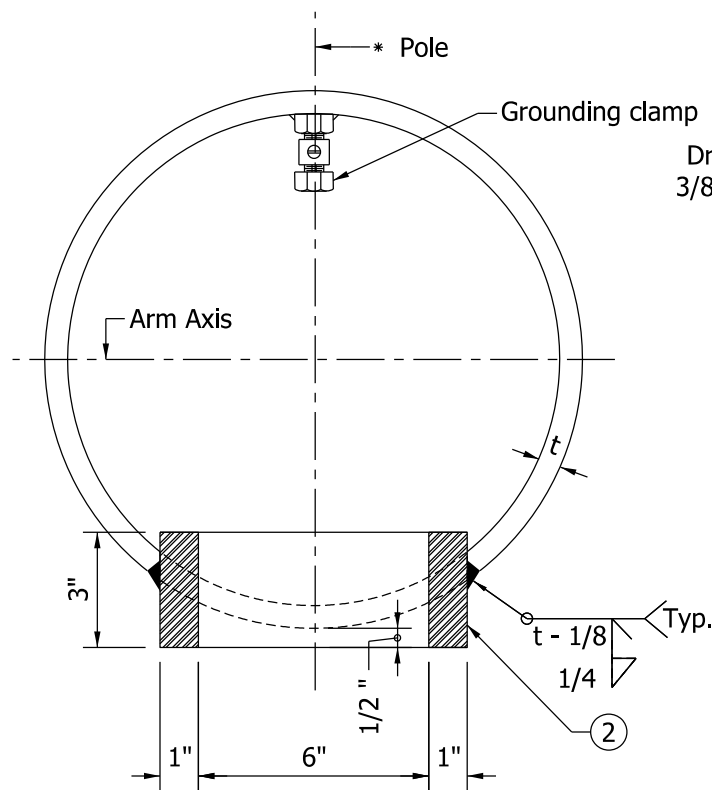

**HANDHOLE A  
SECTION ACROSS POLE**

Drill and tap for 4 screws,  
3/8" - 20 Chase thread after  
galvanizing

1"x 3" flat  
bar frame

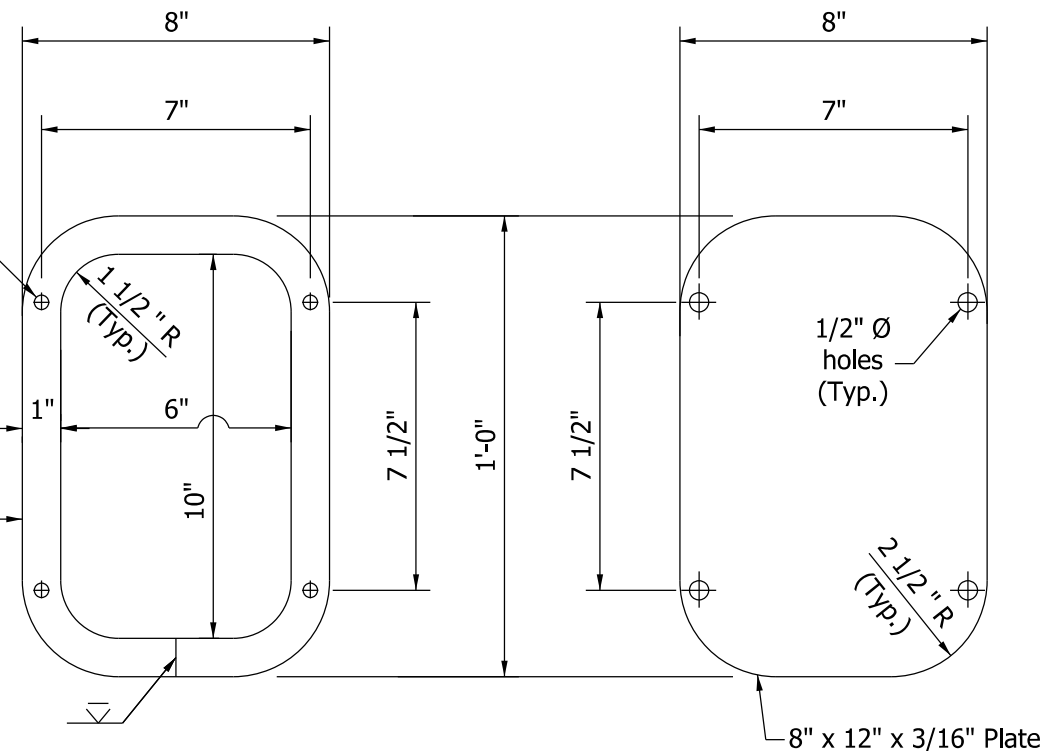

**FRAME DETAIL**

**COVER**

**HANDHOLE A**

INDIANA DEPARTMENT OF TRANSPORTATION		
TRAFFIC SIGNAL CANTILEVER STRUCTURE HANDHOLE DETAILS		
SEPTEMBER 2013		
STANDARD DRAWING NO. E 805-TSCS-06		
	/s/ Alfredo B. Hanza	02/05/13
	DESIGN STANDARDS ENGINEER	DATE
	/s/ Mark A. Miller	03/27/13
	CHIEF ENGINEER	DATE

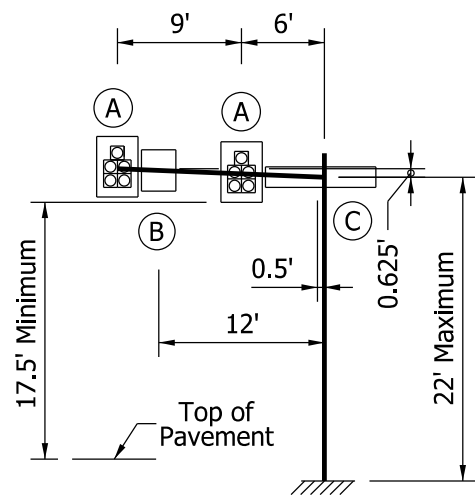

**15' ARM**

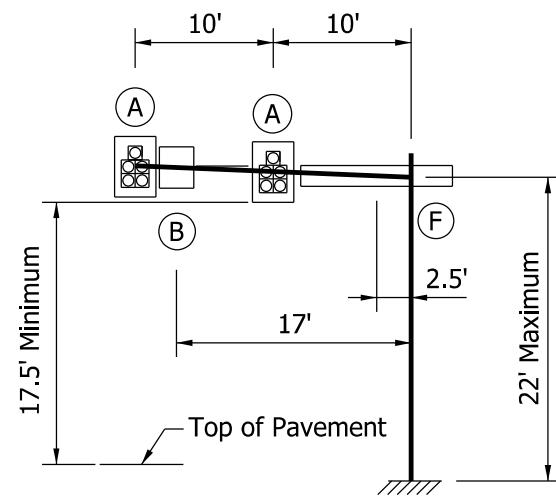

**20' ARM**

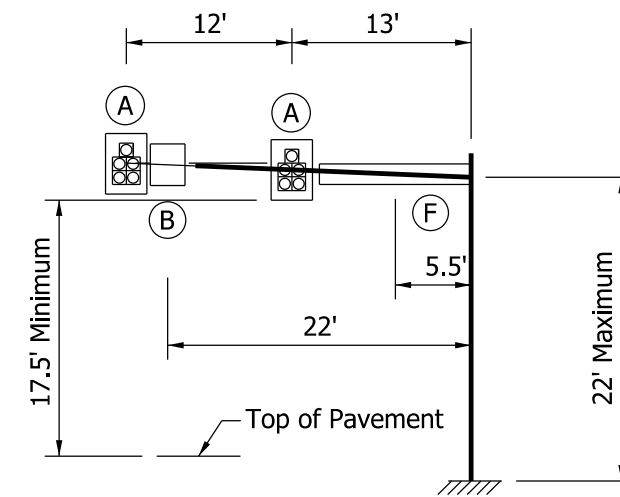

**25' ARM**

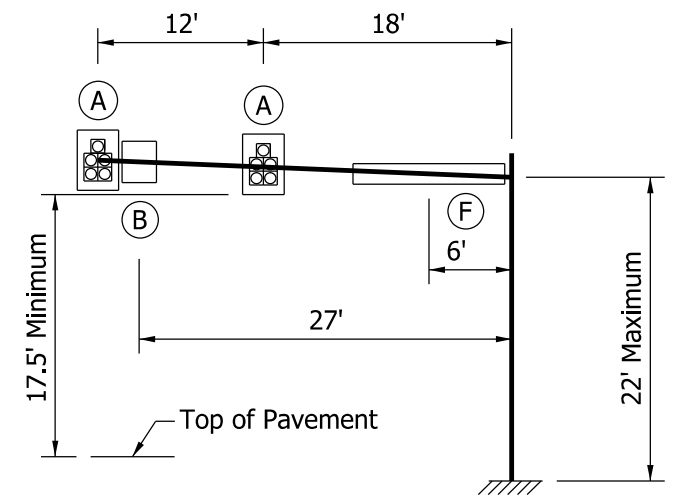

**30' ARM**

**NOTE:**

1. The structure arms and pole are designed for the above loading conditions. Foundation types A and C are designed for arms having length of 35 ft or less. See Standard Drawings E 805-TSCS-16 and -18 for foundation types A and C.

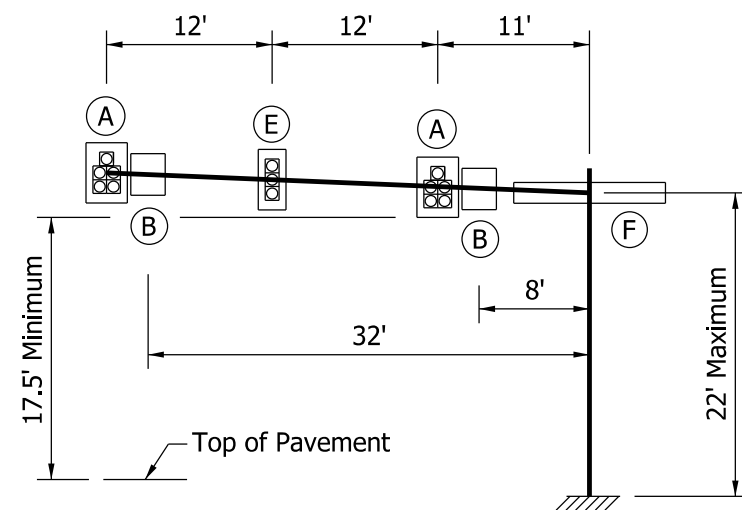

**35' ARM**

LEGEND	
Device	Description
(A)	12" - 5 Section Signal Head With Backplates
(B)	36" x 30" Regulatory Sign
(C)	18" x 96" Street Name Sign
(E)	12" - 3 Section Signal Head With Backplates
(F)	18" x 132" Street Name Sign

**INDIANA DEPARTMENT OF TRANSPORTATION**

**TRAFFIC SIGNAL CANTILEVER STRUCTURE  
PLACEMENT OF SIGNALS AND SIGNS  
LOADING FOR ARM OF 35' OR LESS**

SEPTEMBER 2013

STANDARD DRAWING NO. E 805-TSCS-07

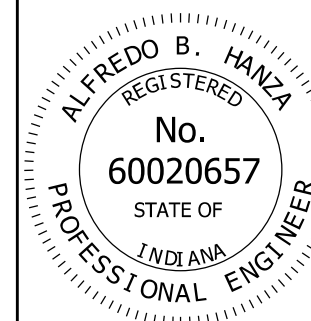

*/s/ Alfredo B. Hanza* 02/05/13

DESIGN STANDARDS ENGINEER DATE

*/s/ Mark A. Miller* 03/27/13

CHIEF ENGINEER DATE

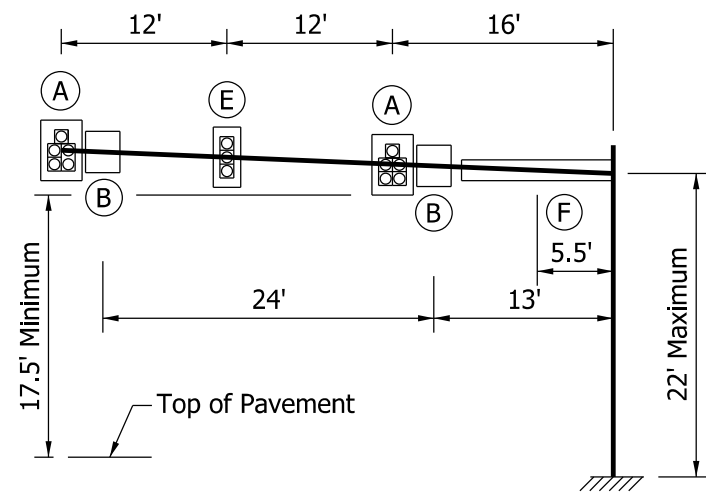

40' ARM

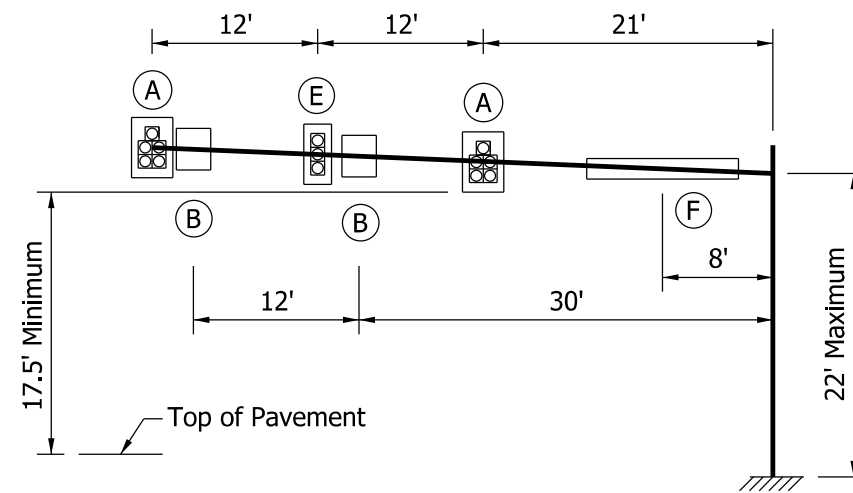

45' ARM

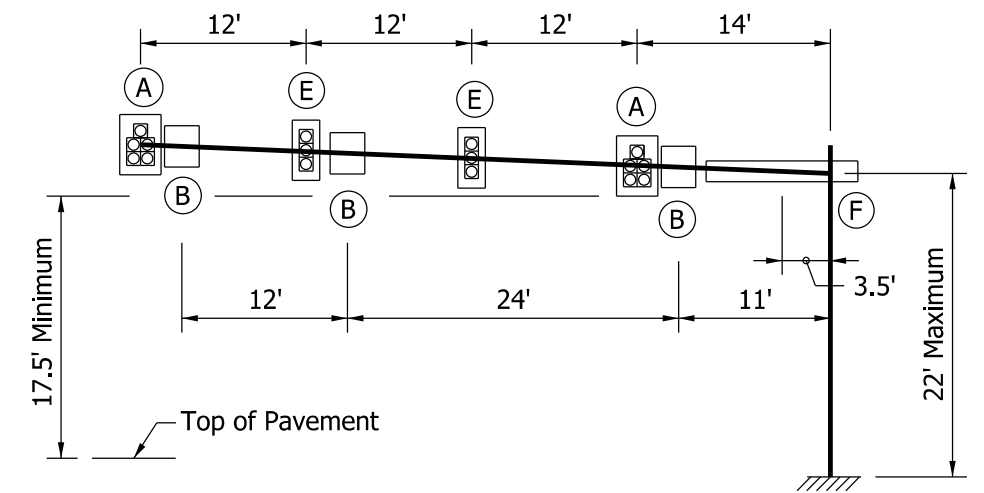

50' ARM

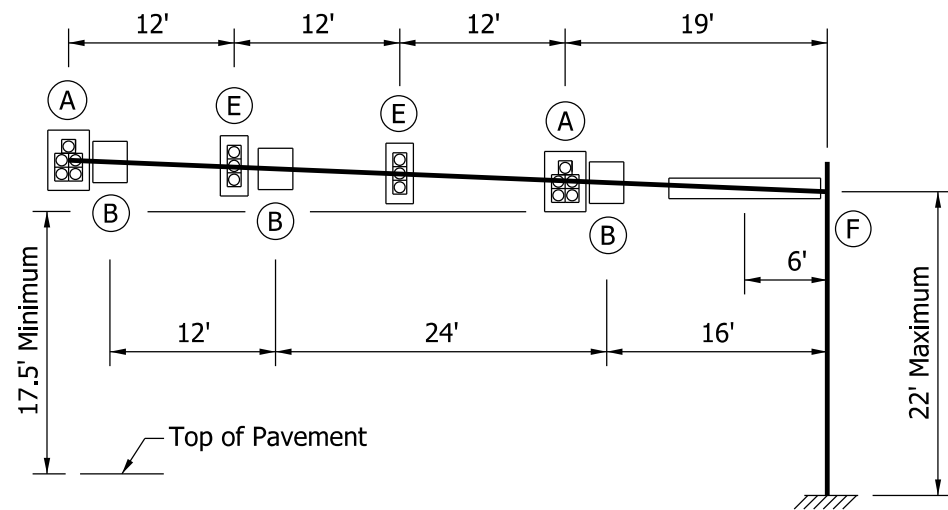

55' ARM

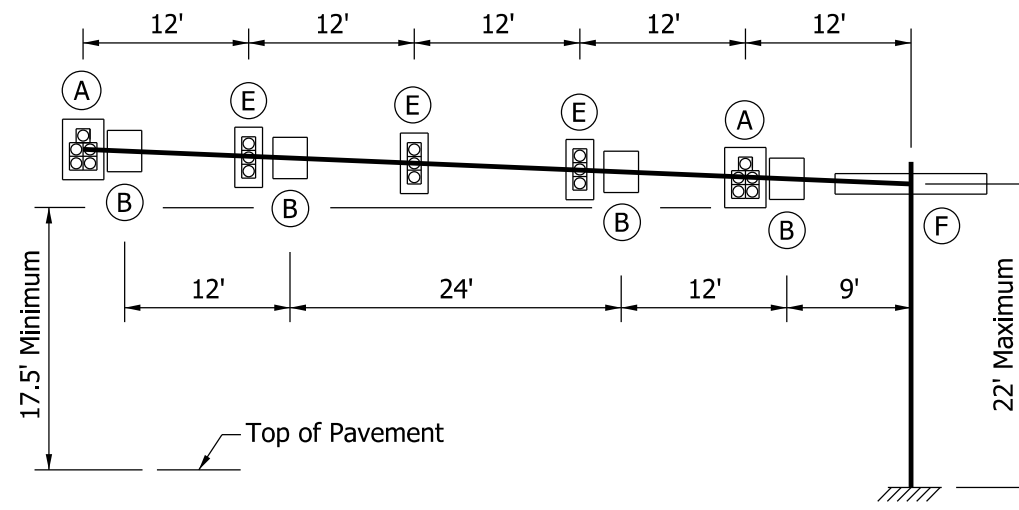

60' ARM

**NOTES:**

1. See Standard Drawing E 805-TSCS-07 for Legend.
2. The structure arms and pole are designed for the above loading conditions. Foundation types B and D are designed for arms having length of greater than 35 ft to 60 ft. See Standard Drawings E 805-TSCS-17 and -19 for foundation types B and D.

INDIANA DEPARTMENT OF TRANSPORTATION	
TRAFFIC SIGNAL CANTILEVER STRUCTURE PLACEMENT OF SIGNALS AND SIGNS LOADING FOR ARM OF GREATER THAN 35' TO 60' SEPTEMBER 2013	
STANDARD DRAWING NO.	E 805-TSCS-08
	/s/ Alfredo B. Hanza      02/05/13 DESIGN STANDARDS ENGINEER      DATE
	/s/ Mark A. Miller      03/27/13 CHIEF ENGINEER      DATE



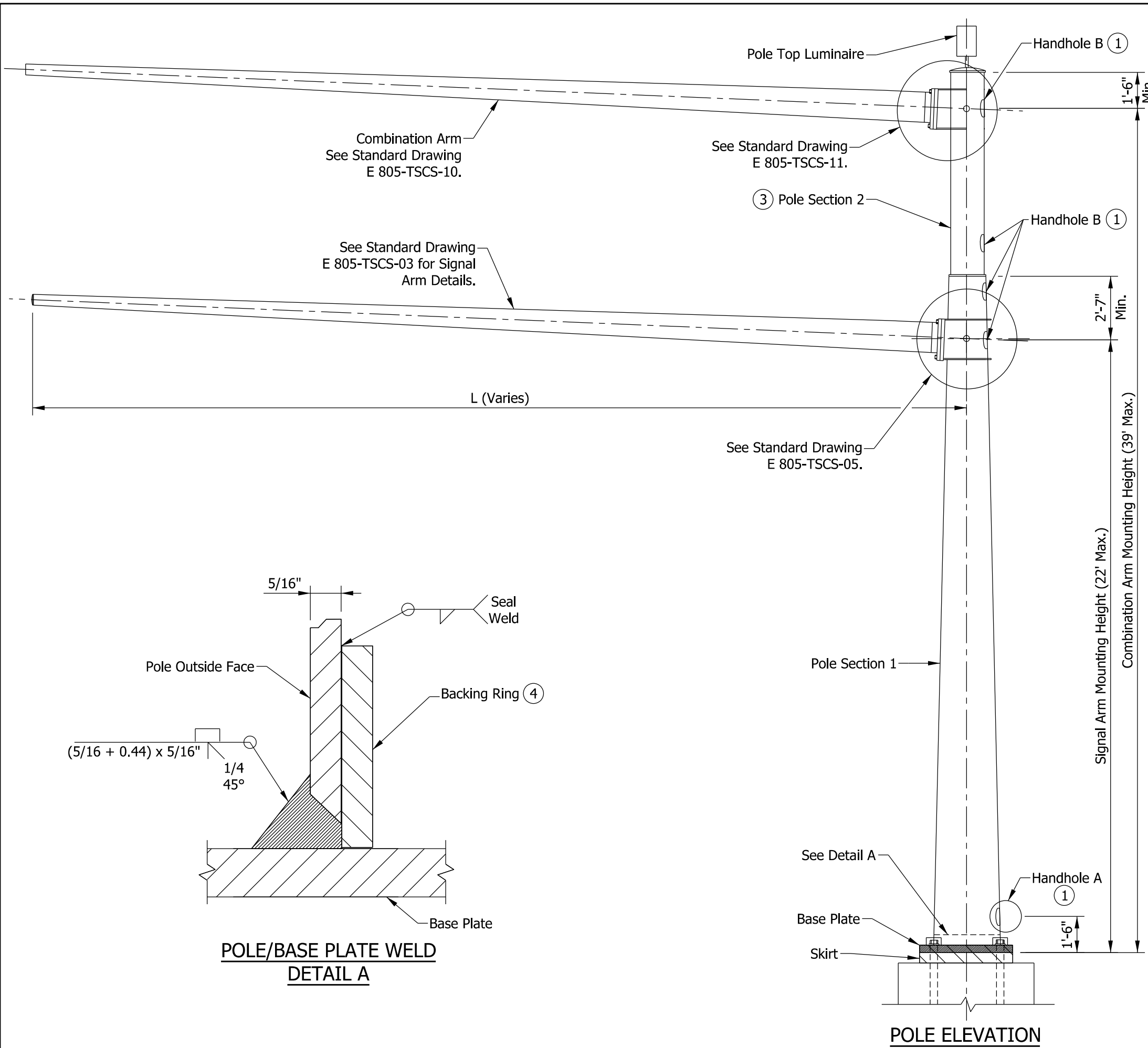

**NOTES:**

- ① See Standard Drawing E 805-TSCS-06 for handhole details.
- 2. See Standard Drawing E 805-SGGR-01 to -03 for grounding details.
- ③ Base diameter of Pole Section 2 shall be equal to top diameter of Pole Section 1.
- ④ Use continuous backing ring, 5/16" x 2" minimum. Tack weld only in root area of final weld.

**VERTICAL CLEARANCE CRITERIA:**  
 Maintain 40'-0" minimum clearance from top of pavement to the camera lens.

POLE DIMENSIONS				
CANTILEVER ARM LENGTH L	POLE SECTION 1		POLE SECTION 2	
	BASE DIAMETER	WALL THICKNESS	BASE DIAMETER	WALL THICKNESS
15' to 35'	17"	5/16"	See Note ③	1/8"
>35' to 60'	24"	5/16"	See Note ③	1/8"

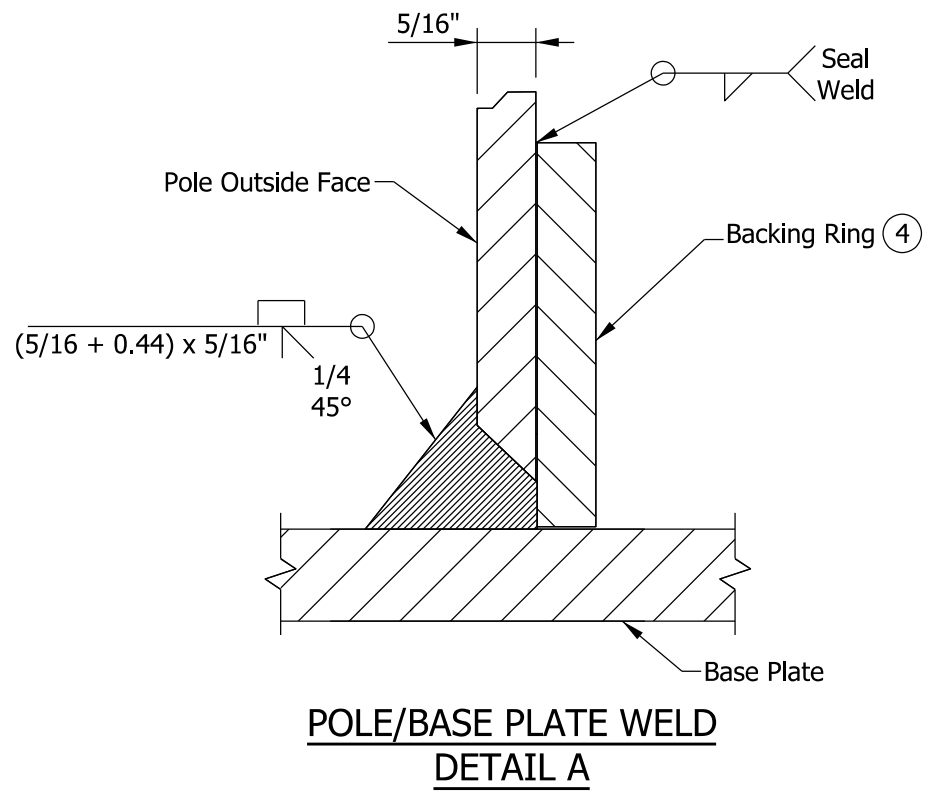

**POLE/BASE PLATE WELD  
 DETAIL A**

**POLE ELEVATION**

**INDIANA DEPARTMENT OF TRANSPORTATION**

**TRAFFIC SIGNAL CANTILEVER STRUCTURE  
 COMBINATION POLE ELEVATION,  
 DIMENSIONS, AND BASE PLATE WELD DETAIL  
 SEPTEMBER 2014**

**STANDARD DRAWING NO. E 805-TSCS-09**

	<table style="width: 100%; border-collapse: collapse;"> <tr> <td style="width: 60%; border-bottom: 1px solid black; padding: 2px;">/s/ <i>Alfredo B. Hanza</i></td> <td style="width: 40%; border-bottom: 1px solid black; padding: 2px;">12/02/13</td> </tr> <tr> <td style="padding: 2px;">DESIGN STANDARDS ENGINEER</td> <td style="padding: 2px;">DATE</td> </tr> <tr> <td style="border-bottom: 1px solid black; padding: 2px;">/s/ <i>Mark A. Miller</i></td> <td style="border-bottom: 1px solid black; padding: 2px;">12/05/13</td> </tr> <tr> <td style="padding: 2px;">CHIEF ENGINEER</td> <td style="padding: 2px;">DATE</td> </tr> </table>	/s/ <i>Alfredo B. Hanza</i>	12/02/13	DESIGN STANDARDS ENGINEER	DATE	/s/ <i>Mark A. Miller</i>	12/05/13	CHIEF ENGINEER	DATE
/s/ <i>Alfredo B. Hanza</i>	12/02/13								
DESIGN STANDARDS ENGINEER	DATE								
/s/ <i>Mark A. Miller</i>	12/05/13								
CHIEF ENGINEER	DATE								

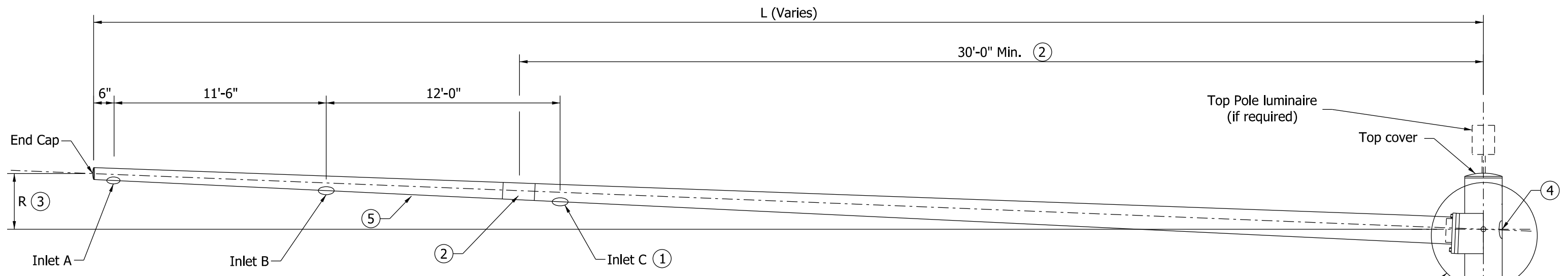

**ELEVATION**

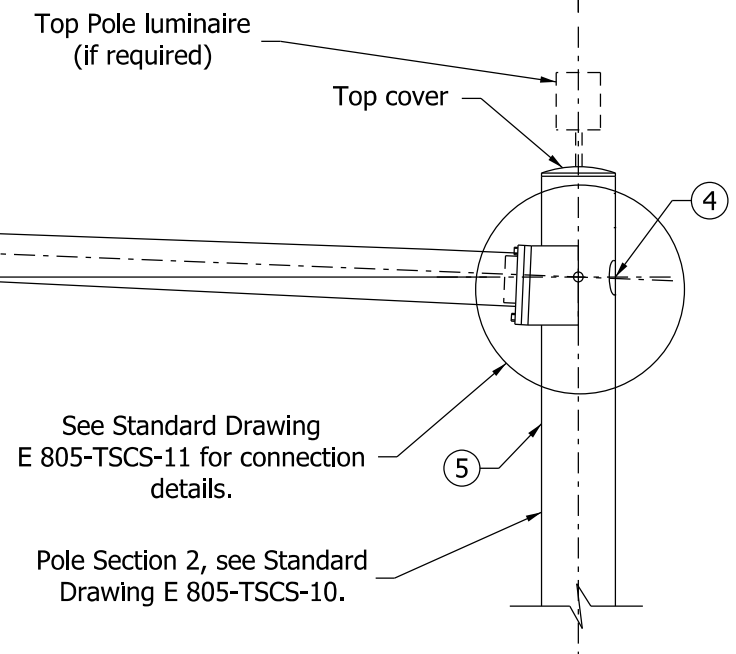

See Standard Drawing E 805-TSCS-11 for connection details.  
Pole Section 2, see Standard Drawing E 805-TSCS-10.

**NOTES:**

- ① Number of cable inlets depends on L. See Arm Dimensions Table. The inlet diameter shall be 1 3/4" with rubber grommet (typ.).
- ② Optional splice can be used for arm length of greater than 40 ft. Field assembly shall achieve a snug tight joint having overlap not less than 1.5 times the inside dimension of the end section.
- ③ Arm rise R is measured in the undeflected position without vertical loads on the arm.
- ④ See Standard Drawing E 805-TSCS-06 for handhole details.
- ⑤ If seam welds are used, the weld location for the arms shall be along the bottom, and on the side of the pole as shown.

End section extension with wall thickness 1/8" and with drilled hole for 5/8" bolt

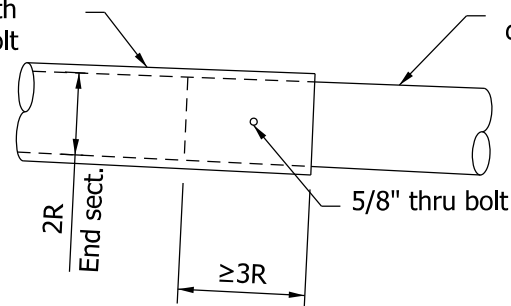

Base section with wall thickness 5/16" and field drilled hole for 5/8" bolt with curved washer and lock nut

**② OPTIONAL ARM SPLICE DETAIL**

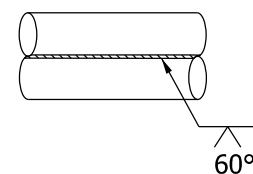

**⑤ TYPICAL SEAM WELD**

**ARM DIMENSIONS TABLE**

L	ARM DIAMETER AT POLE	ARM WALL THICKNESS	R ③	CABLE INLETS ①
15'	5 1/2"	1/8"	7 1/2"	A
20'	5 1/2"	1/8"	10"	A
25'	7"	1/8"	1'-0 1/2"	A
30'	8"	1/8"	1'-3"	A, B
35'	8"	1/8"	1'-5 1/2"	A, B
40'	9"	1/8"	1'-8"	A, B, C
45'	10"	1/8"	1'-10 1/2"	A, B, C
50'	11"	1/8"	2'-1"	A, B, C
55'	11"	1/8"	2'-3 1/2"	A, B, C
60'	12"	1/8"	2'-6"	A, B, C

INDIANA DEPARTMENT OF TRANSPORTATION

TRAFFIC SIGNAL CANTILEVER STRUCTURE  
COMBINATION ARM DIMENSIONS & DETAILS

SEPTEMBER 2013

STANDARD DRAWING NO. E 805-TSCS-10

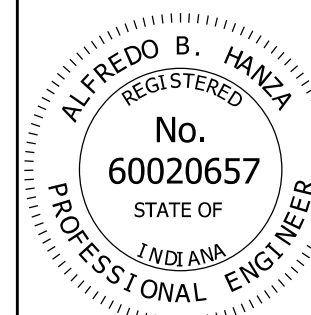

/s/ Alfredo B. Hanza 02/05/13  
DESIGN STANDARDS ENGINEER DATE

/s/ Mark A. Miller 03/27/13  
CHIEF ENGINEER DATE

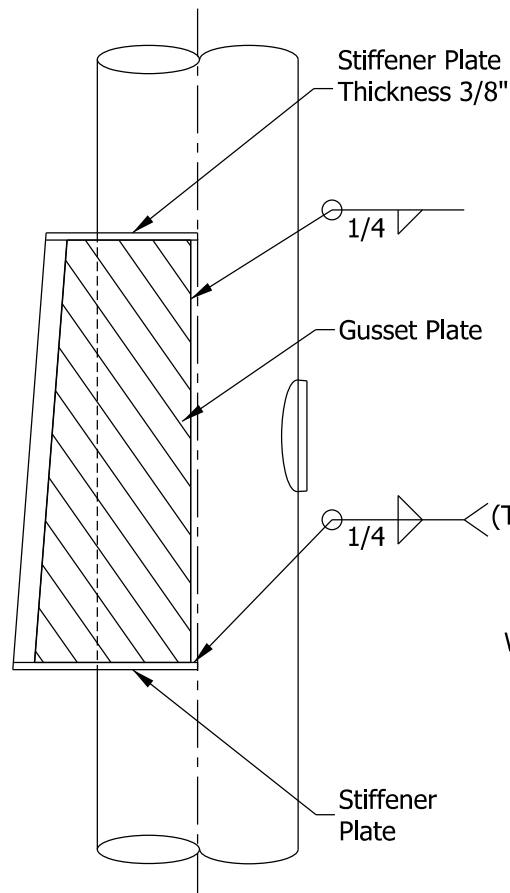

**ELEVATION OF GUSSET PLATES**

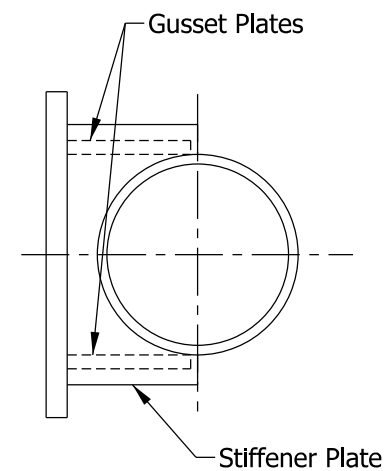

**TOP OF GUSSET PLATES**

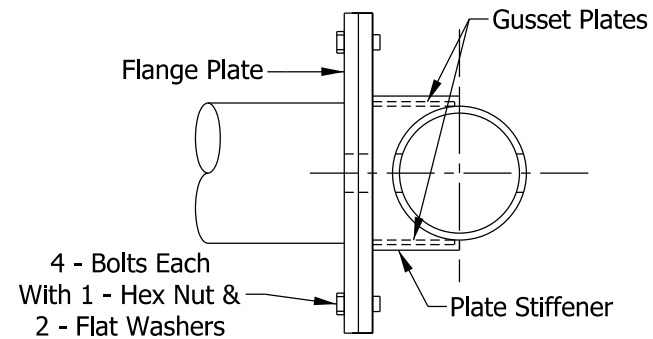

**SECTION G-G**

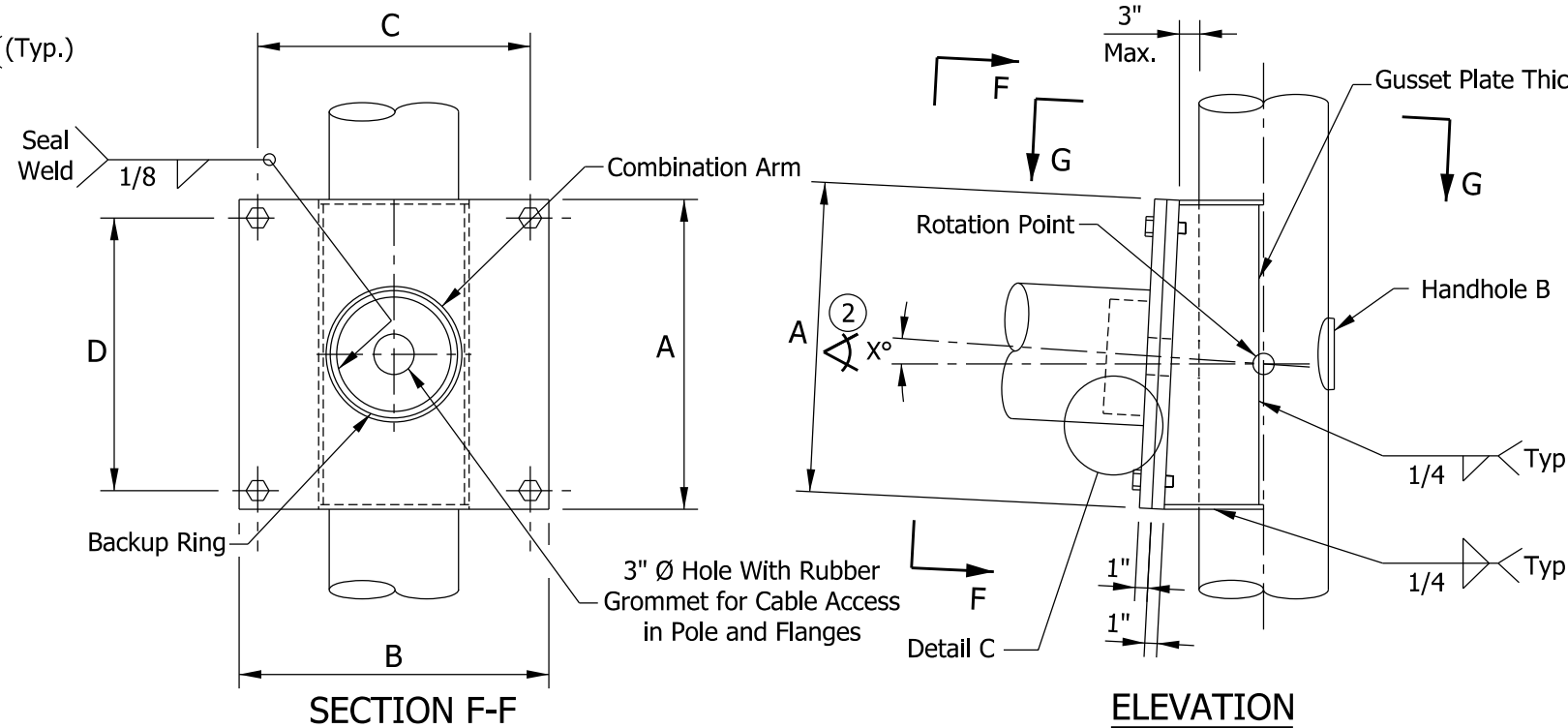

**COMBINATION ARM CONNECTION DETAIL**

PLATES AND BOLTS FOR COMBINATION ARM CANTILEVER				
ARM LENGTH	FLANGE PLATE A x B	BOLT PATTERN C x D	FLANGE PLATE THICKNESS	BOLT
15' to 35'	20" x 20"	17" x 17"	1"	7/8" - 9 UNC x 3.5" Long
>35' to 60'	25" x 25"	22" x 22"	1"	7/8" - 9 UNC x 3.5" Long

**NOTES:**

1. See Standard Drawing E 805-TSCS-06 for handhole details.
2. The required combination arm rise shall be built into the gusset plate at the angle X. The angle X is described as arc tan R/L, where R is the combination arm rise and L is the arm length. Both R and L vary and are listed in the Arm Dimensions Table on Standard Drawing E 805-TSCS-03.
3. Use continuous backing ring, 5/16" x 2" minimum. Tack weld only in root area of final weld.

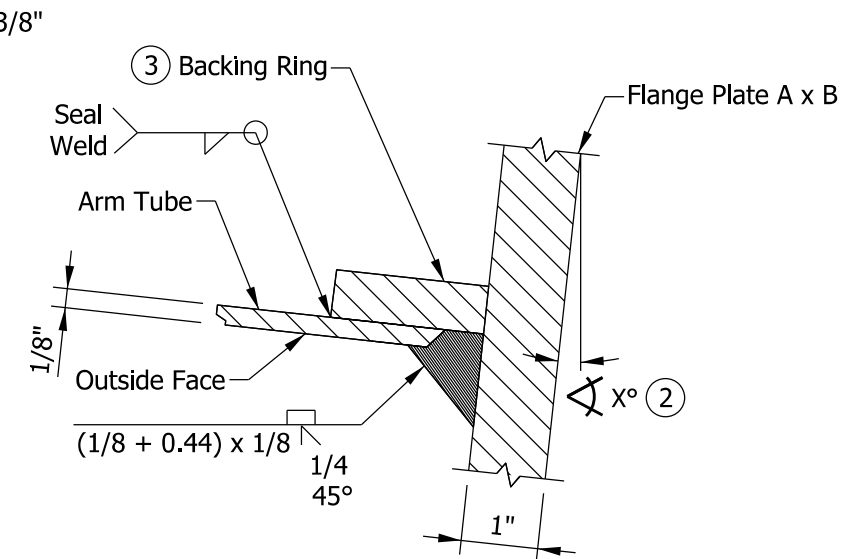

**DETAIL C - ARM WELD**

INDIANA DEPARTMENT OF TRANSPORTATION

TRAFFIC SIGNAL CANTILEVER STRUCTURE  
COMBINATION ARM CONNECTION DETAILS

SEPTEMBER 2014

STANDARD DRAWING NO. E 805-TSCS-11

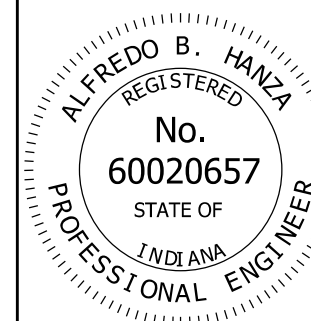

/s/ Alfredo B. Hanza 12/02/13

DESIGN STANDARDS ENGINEER DATE

/s/ Mark A. Miller 12/05/13

CHIEF ENGINEER DATE

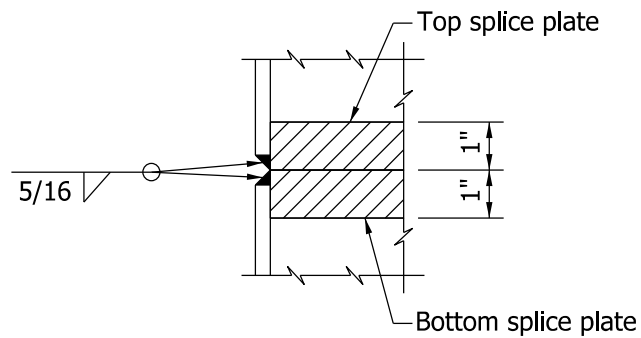

**WELD DETAIL D**

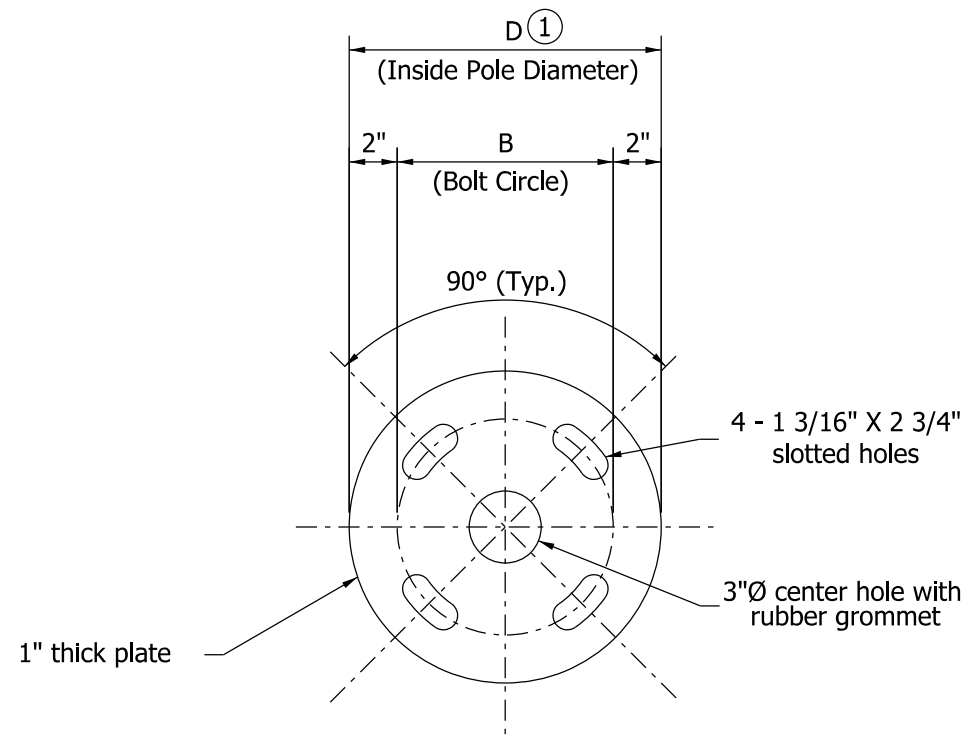

**TOP SPLICE PLATE**

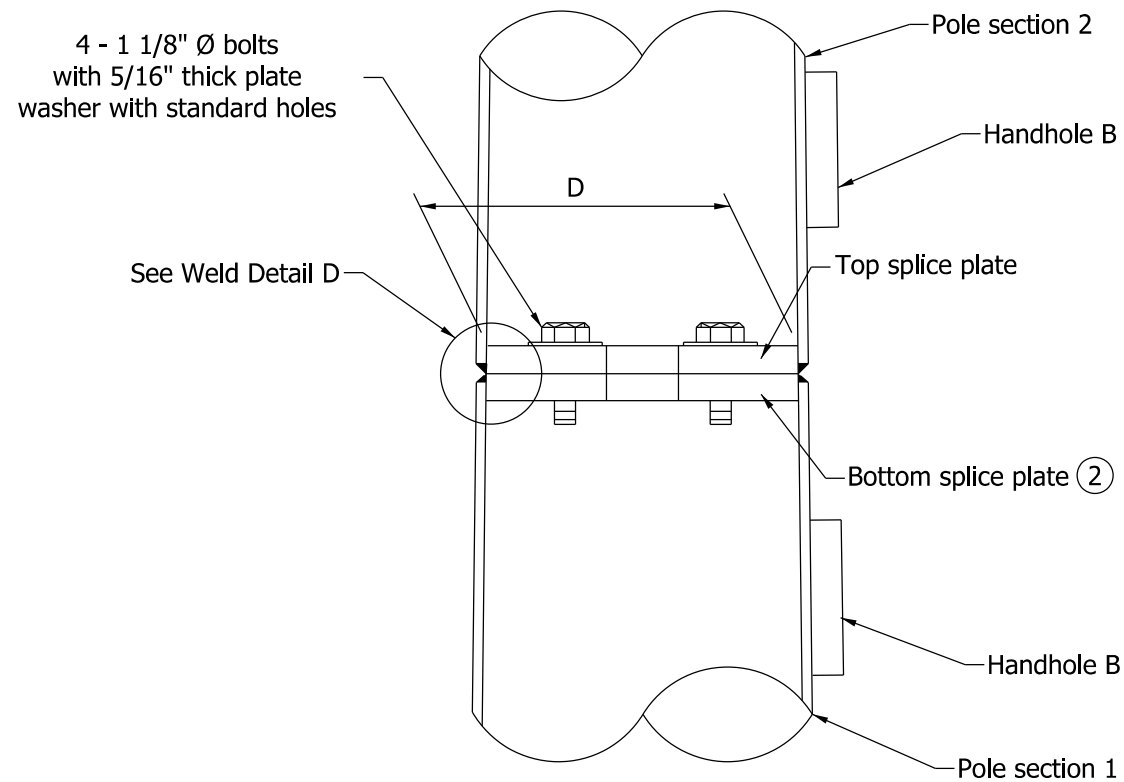

**ELEVATION**

**NOTES:**

- ① See Standard Drawing E 805-TSCS-09 for pole dimensions.
- ② See Standard Drawings E 805-TSCS-04 and -13 for bottom splice plate details.
- 3. Diameter at the bottom of Pole Section 2 shall match the diameter at the top of Pole Section 1.

INDIANA DEPARTMENT OF TRANSPORTATION

TRAFFIC SIGNAL CANTILEVER STRUCTURE  
COMBINATION POLE SPLICE DETAILS  
FOR ARMS 35' OR LESS

SEPTEMBER 2013

STANDARD DRAWING NO. E 805-TSCS-12

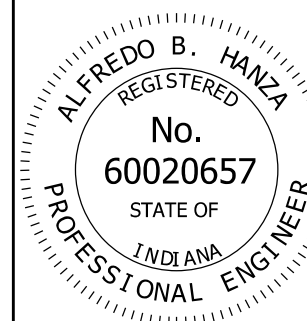

/s/ Alfredo B. Hanza 02/05/13

DESIGN STANDARDS ENGINEER DATE

/s/ Mark A. Miller 03/27/13

CHIEF ENGINEER DATE

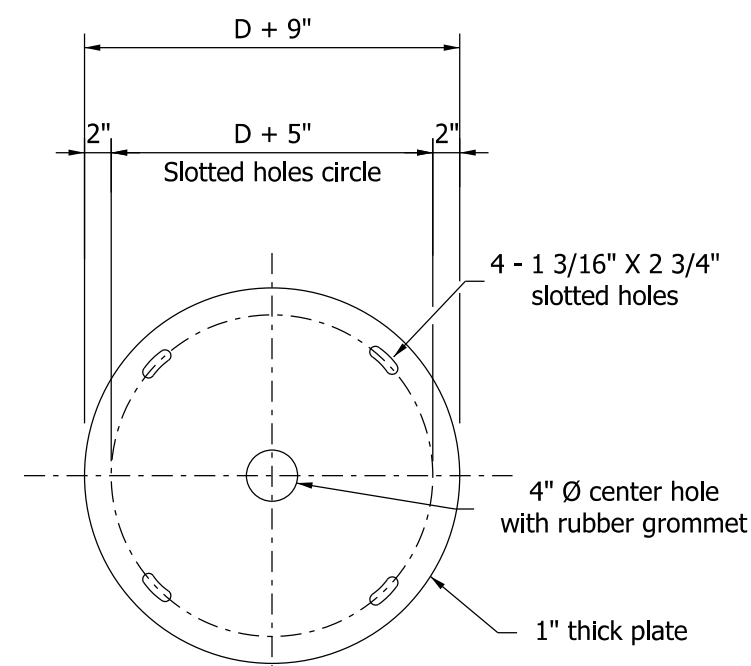

③ **TOP CONNECTION PLATE**

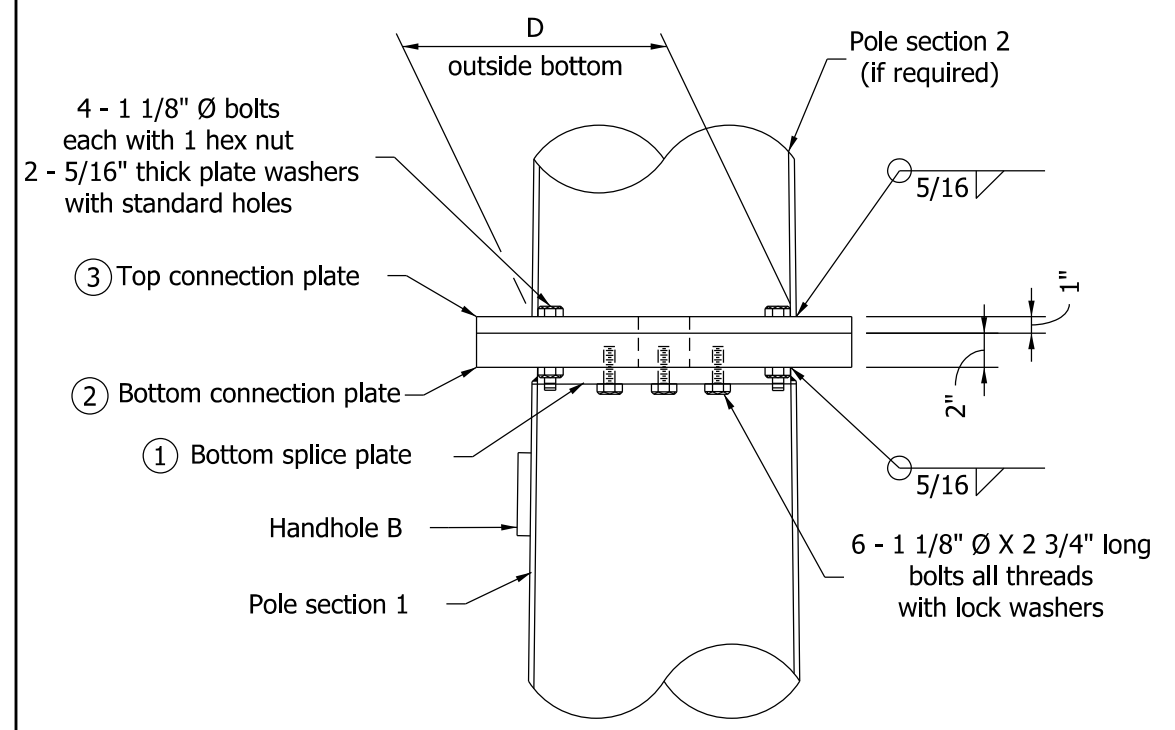

**ELEVATION**

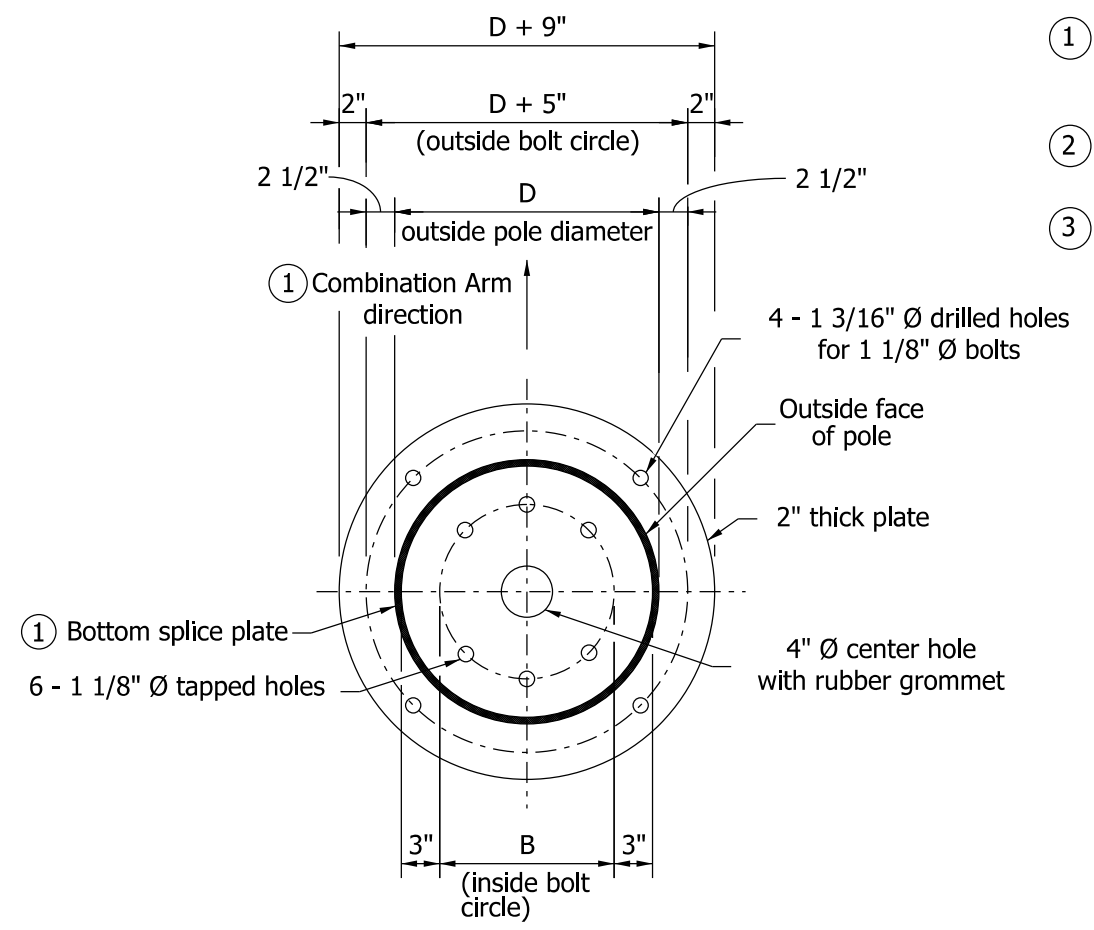

② **BOTTOM CONNECTION PLATE**

**NOTES:**

- ① Orient bottom splice and bottom connection plates with combination arm as shown on the bottom splice plate detail on Standard Drawings E 805-TSCS-04 and -12.
- ② All plate dimensions shall be based upon the outside diameter D at the top of pole section 1.
- ③ Diameter at bottom of pole section 2 shall match the diameter at the top of pole section 1.

INDIANA DEPARTMENT OF TRANSPORTATION	
TRAFFIC SIGNAL CANTILEVER STRUCTURE COMBINATION POLE SPLICE DETAILS FOR ARM OF GREATER THAN 35' TO 60' SEPTEMBER 2013	
STANDARD DRAWING NO. E 805-TSCS-13	
	/s/ <i>Alfredo B. Hanza</i> 02/05/13 DESIGN STANDARDS ENGINEER      DATE
	/s/ <i>Mark A. Miller</i> 03/27/13 CHIEF ENGINEER      DATE

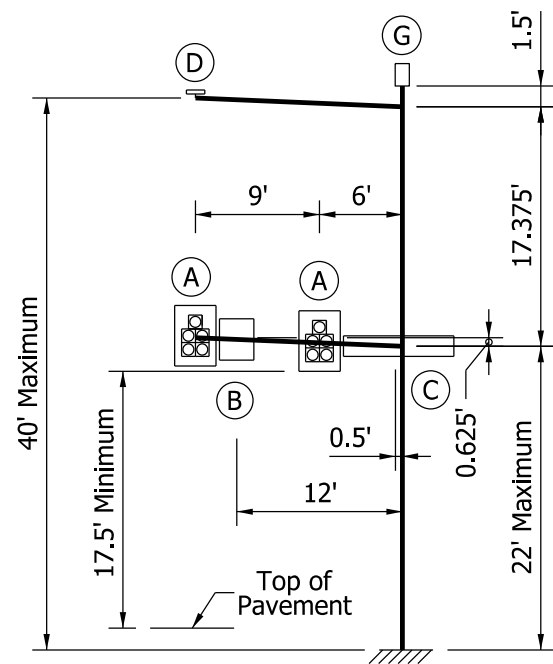

**15' ARM**

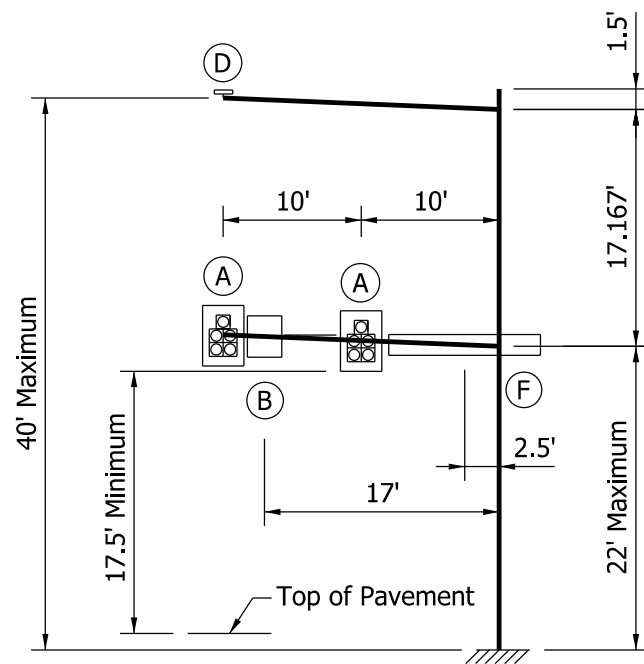

**20' ARM**

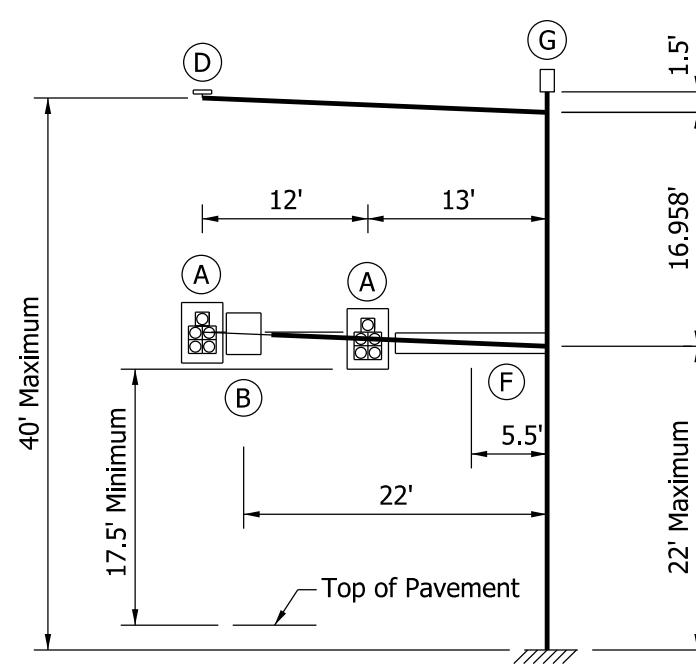

**25' ARM**

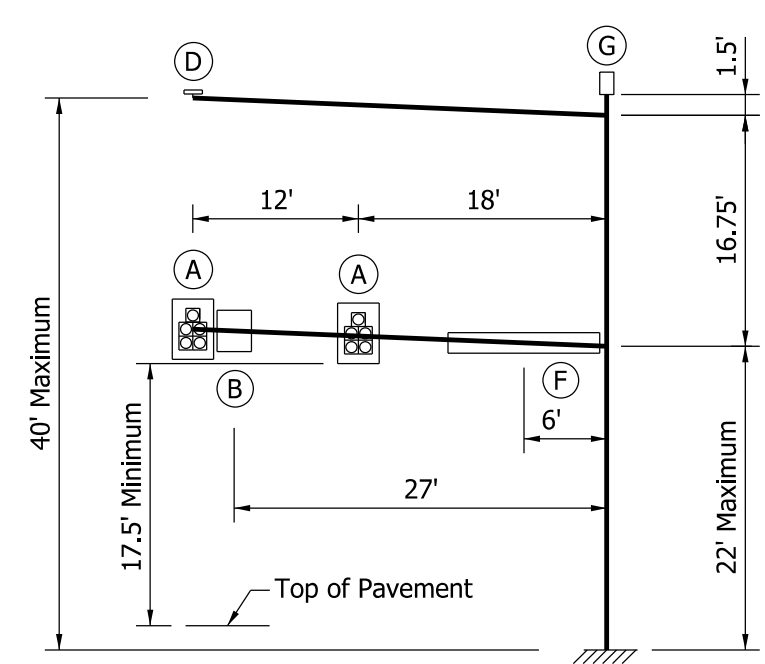

**30' ARM**

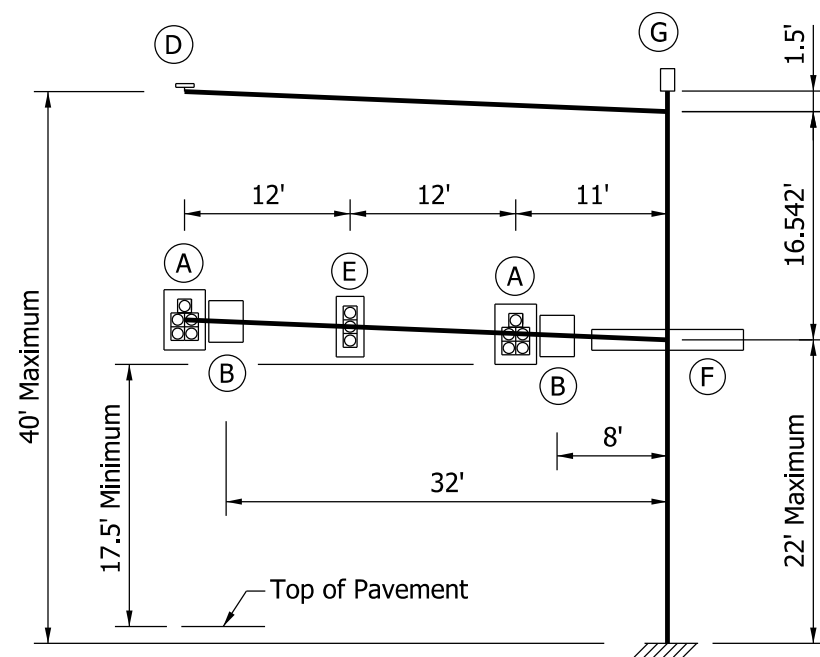

**35' ARM**

LEGEND	
DEVICE	DESCRIPTION
(A)	12" - 5 Section Signal Head With Backplates
(B)	36" x 30" Regulatory Sign
(C)	18" x 96" Street Name Sign
(D)	1 - Mounted Camera
(E)	12" - 3 Section Signal Head With Backplates
(F)	18" x 132" Street Name Sign
(G)	Top Pole Luminaire

**NOTE:**

- The structure arms and pole are designed for the above loading conditions. Foundation types A and C are designed for arms having length of 35 ft or less. See Standard Drawings E 805-TSCS-16 and -18 for foundation types A and C.

<b>INDIANA DEPARTMENT OF TRANSPORTATION</b>	
<b>TRAFFIC SIGNAL CANTILEVER STRUCTURE COMBINATION ARM LOADING FOR ARM OF 35' OR LESS SEPTEMBER 2013</b>	
<b>STANDARD DRAWING NO. E 805-TSCS-14</b>	
	/s/ <i>Alfredo B. Hanza</i> 02/05/13
	DESIGN STANDARDS ENGINEER      DATE
	/s/ <i>Mark A. Miller</i> 03/27/13
	CHIEF ENGINEER      DATE

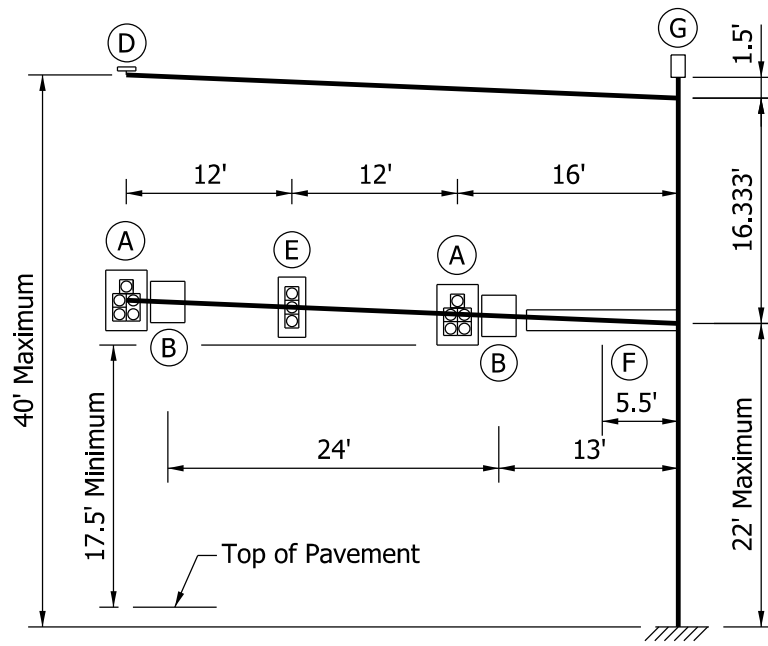

40' ARM

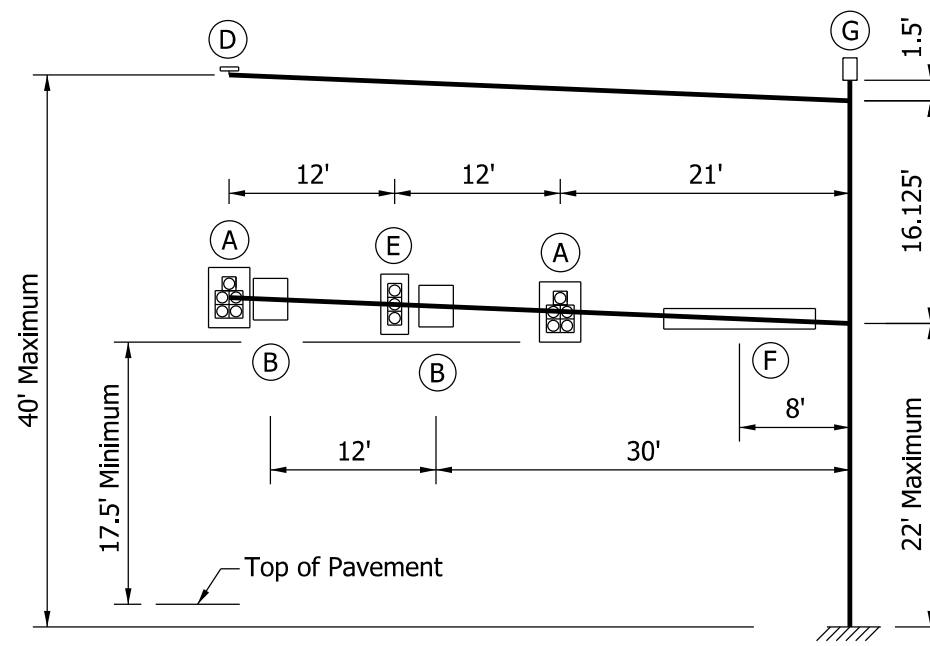

45' ARM

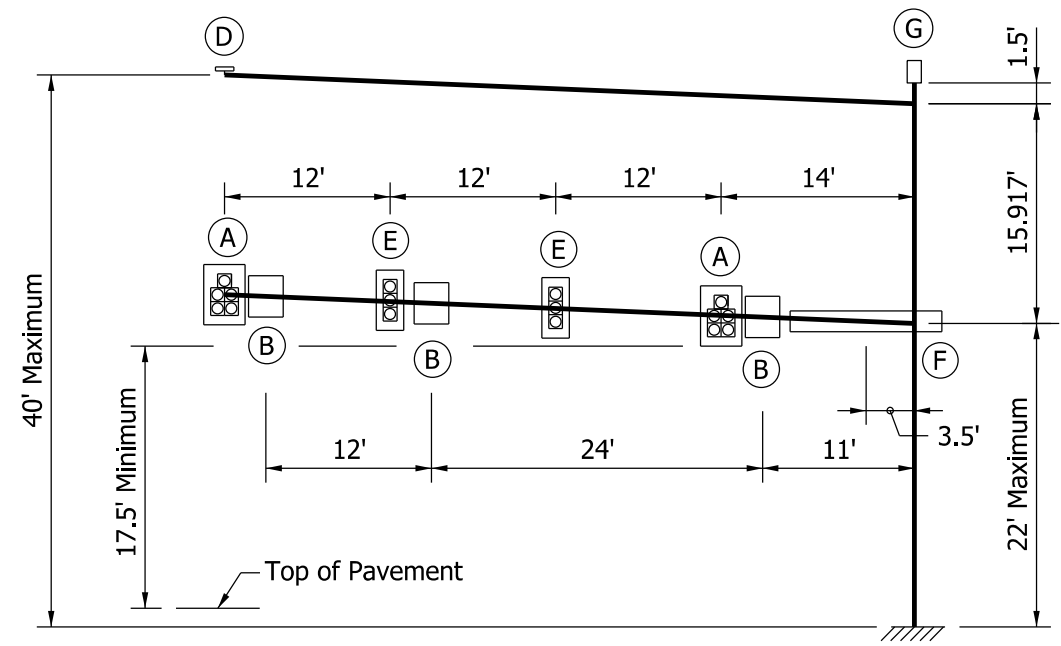

50' ARM

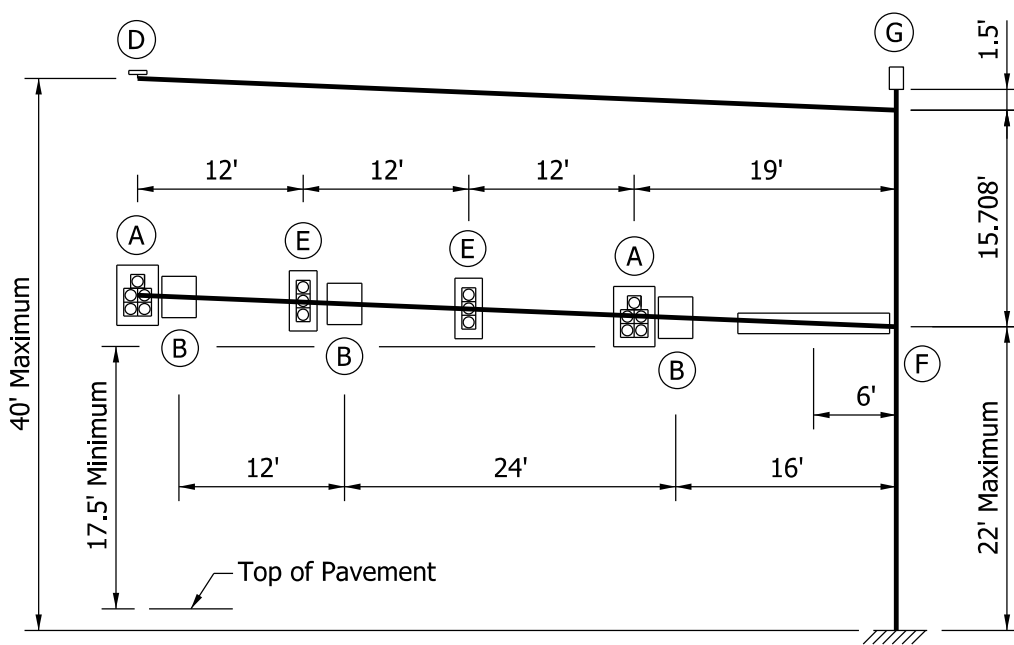

55' ARM

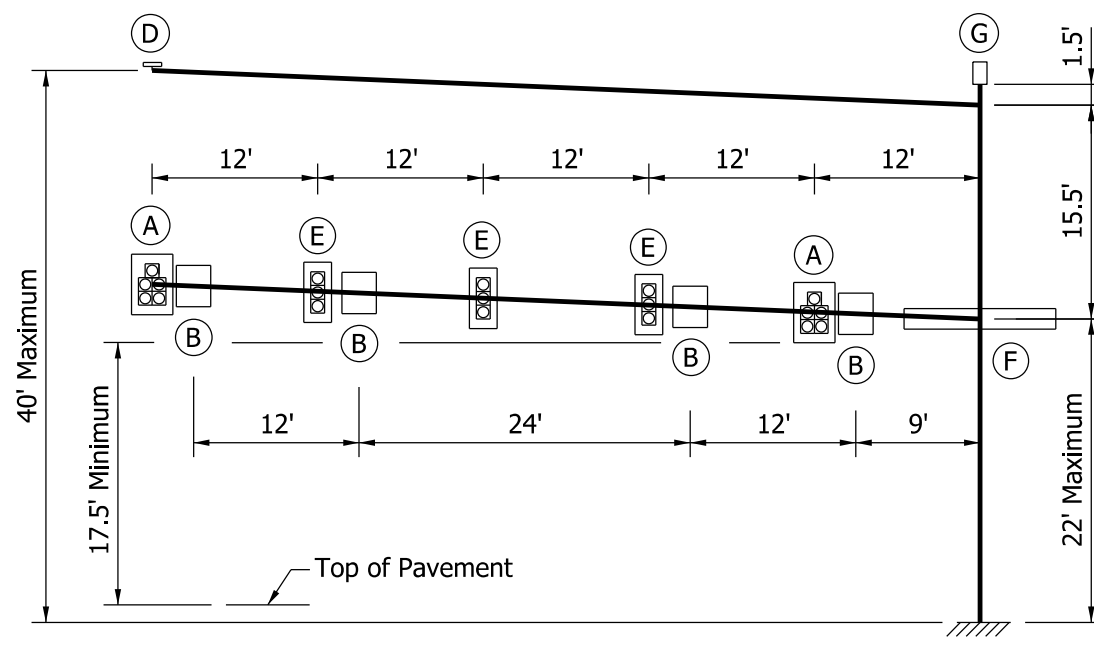

60' ARM

**NOTES:**

1. See Standard Drawing E 805-TSCS-14 for Legend.
2. The structure arms and pole are designed for the above loading conditions. Foundation types B and D are designed for arms having length of greater than 35 ft to 60 ft. See Standard Drawings E 805-TSCS-17 and -19 for foundation types B and D.

INDIANA DEPARTMENT OF TRANSPORTATION	
TRAFFIC SIGNAL CANTILEVER STRUCTURE COMBINATION ARM LOADING FOR ARM OF GREATER THAN 35' TO 60' SEPTEMBER 2013	
STANDARD DRAWING NO.	E 805-TSCS-15
	/s/ Alfredo B. Hanza      02/05/13 DESIGN STANDARDS ENGINEER      DATE
	/s/ Mark A. Miller      03/27/13 CHIEF ENGINEER      DATE

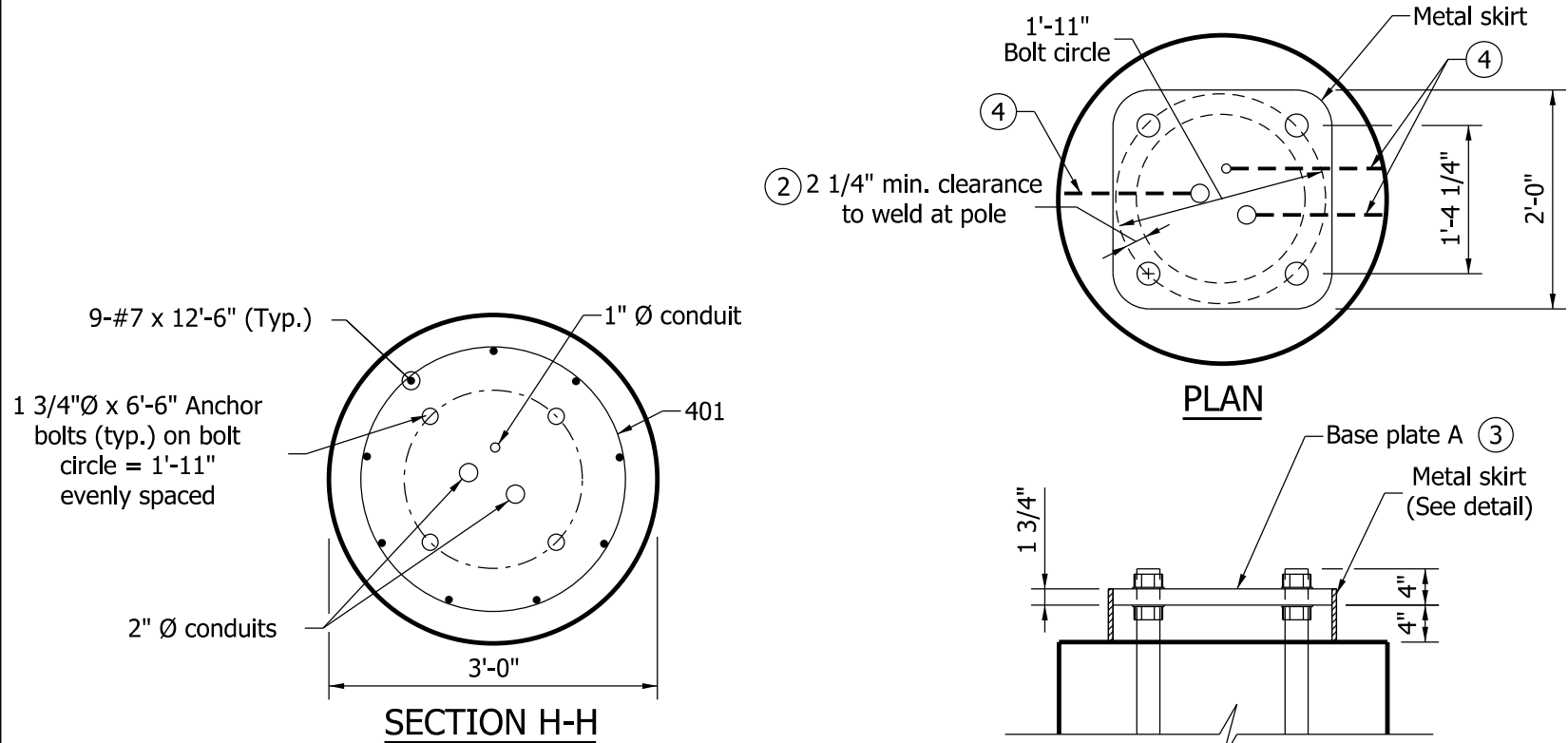

- NOTES:**
- 1 Alternate 6" x 6" x 1/2" square washer with hex nut welded to lower end may be substituted for bent anchor bolt.
  - 2 Bolt circle, b, shall allow clearance for the plate washer. Cutting or trimming the washer will not be allowed.
  - 3 See Standard Drawing E 805-TSCS-04 for base plate A details.
  - 4 A tooled line or other type of permanent marking shall be provided on the top of the foundation to indicate the direction of the conduit.

BILL OF MATERIALS DRILLED SHAFT TYPE A			
REINFORCING BARS			
SIZE OR MARK	NUMBER OF BARS	LENGTH (ft.)	WEIGHT (lbs.)
#7	9	12'-6"	
Total #7			230
401	14	9'-5"	
Total #4			88
Total Reinforcing Bars			318
CONCRETE			
Concrete, Class A			3.4 CYS

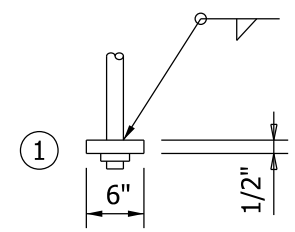
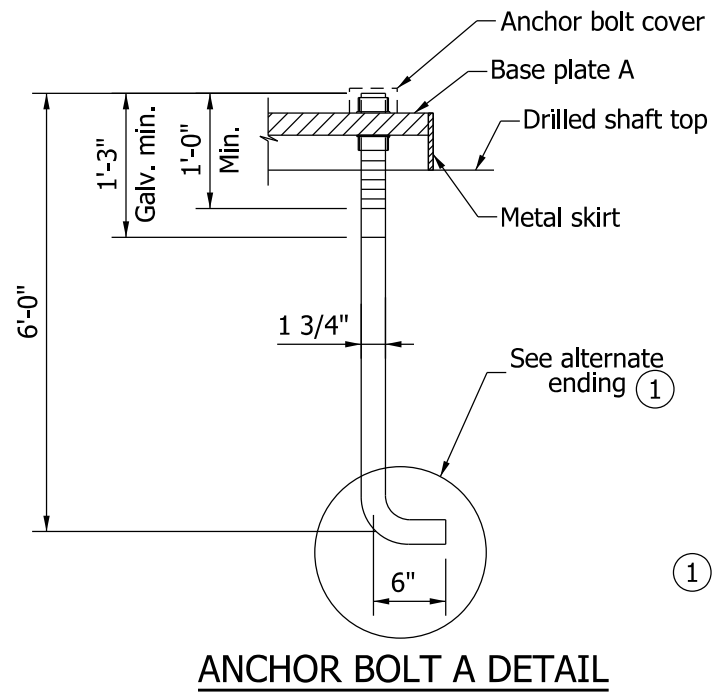
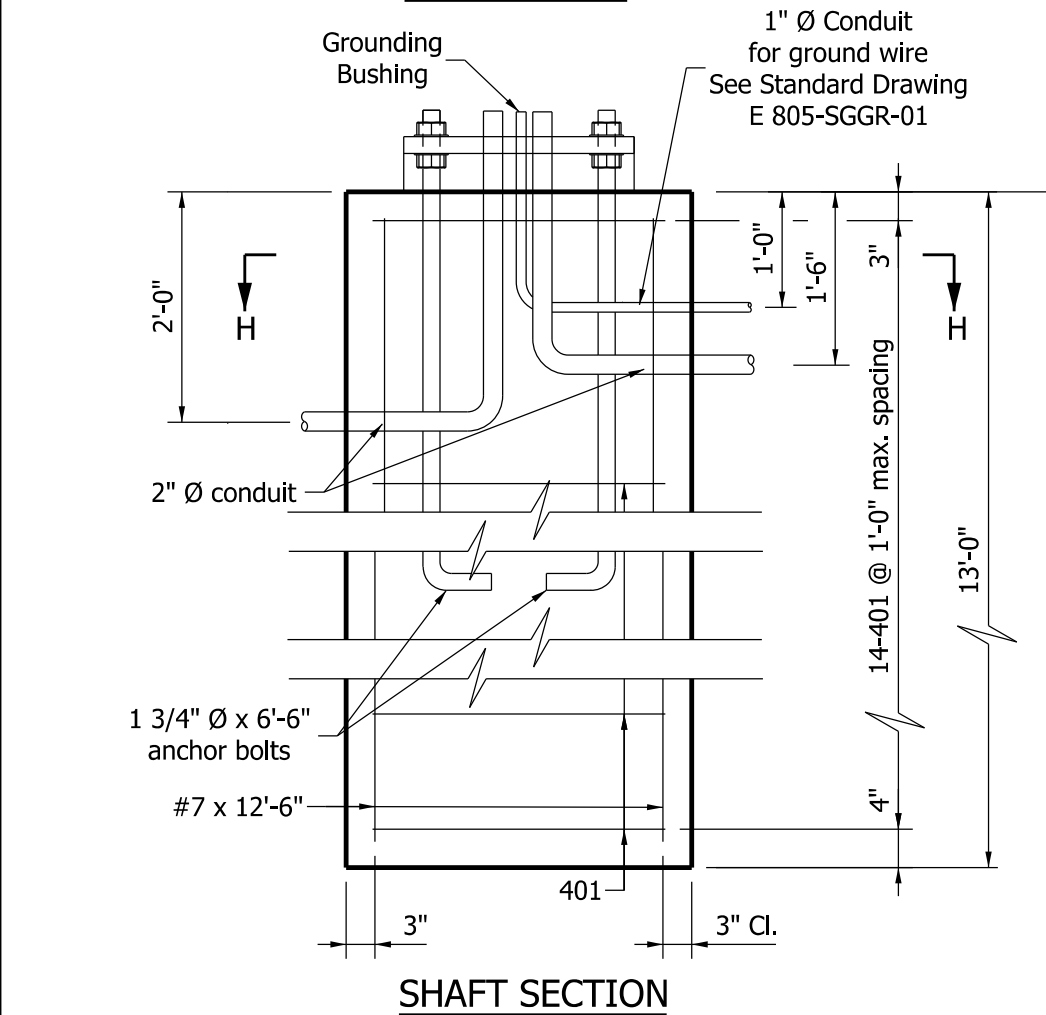
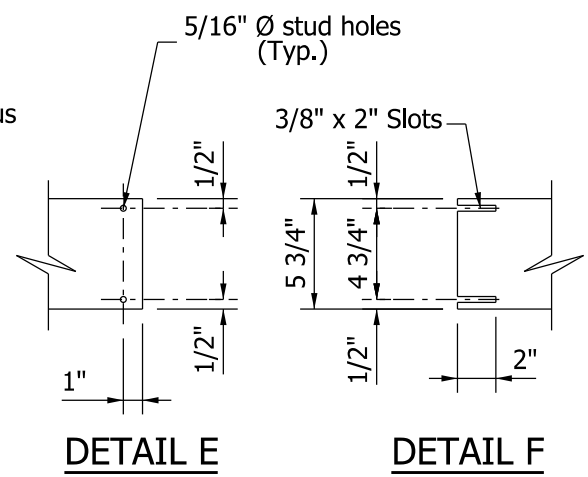
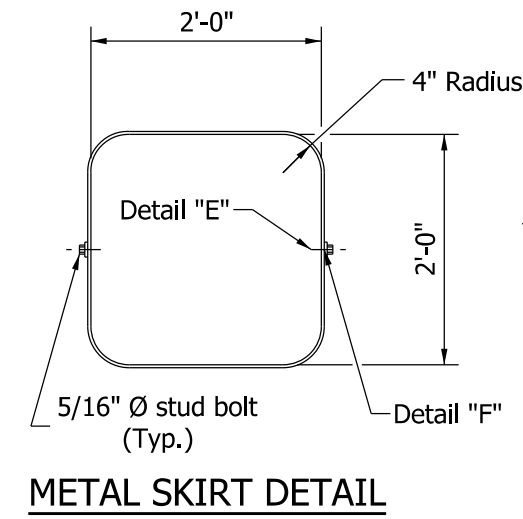
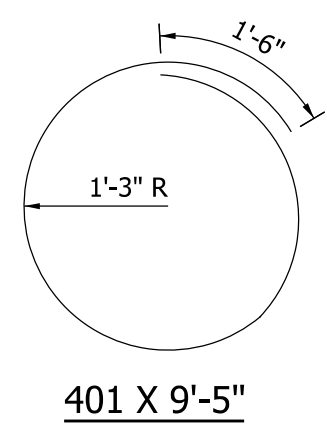
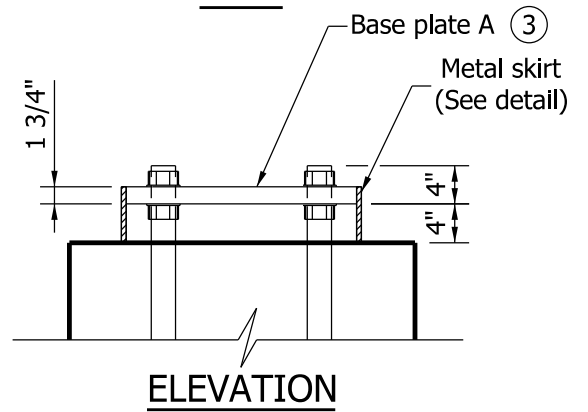

**INDIANA DEPARTMENT OF TRANSPORTATION**

**TRAFFIC SIGNAL CANTILEVER STRUCTURE  
DRILLED SHAFT FOUNDATION TYPE A  
FOR ARM OF 35' OR LESS**

**SEPTEMBER 2013**

---

STANDARD DRAWING NO. **E 805-TSCS-16**

	<table border="0" style="width: 100%;"> <tr> <td style="width: 70%;"><i>/s/ Alfredo B. Hanza</i></td> <td style="width: 30%; text-align: right;">02/05/13</td> </tr> <tr> <td>DESIGN STANDARDS ENGINEER</td> <td style="text-align: right;">DATE</td> </tr> <tr> <td colspan="2"><hr/></td> </tr> <tr> <td><i>/s/ Mark A. Miller</i></td> <td style="text-align: right;">03/27/13</td> </tr> <tr> <td>CHIEF ENGINEER</td> <td style="text-align: right;">DATE</td> </tr> </table>	<i>/s/ Alfredo B. Hanza</i>	02/05/13	DESIGN STANDARDS ENGINEER	DATE	<hr/>		<i>/s/ Mark A. Miller</i>	03/27/13	CHIEF ENGINEER	DATE
<i>/s/ Alfredo B. Hanza</i>	02/05/13										
DESIGN STANDARDS ENGINEER	DATE										
<hr/>											
<i>/s/ Mark A. Miller</i>	03/27/13										
CHIEF ENGINEER	DATE										



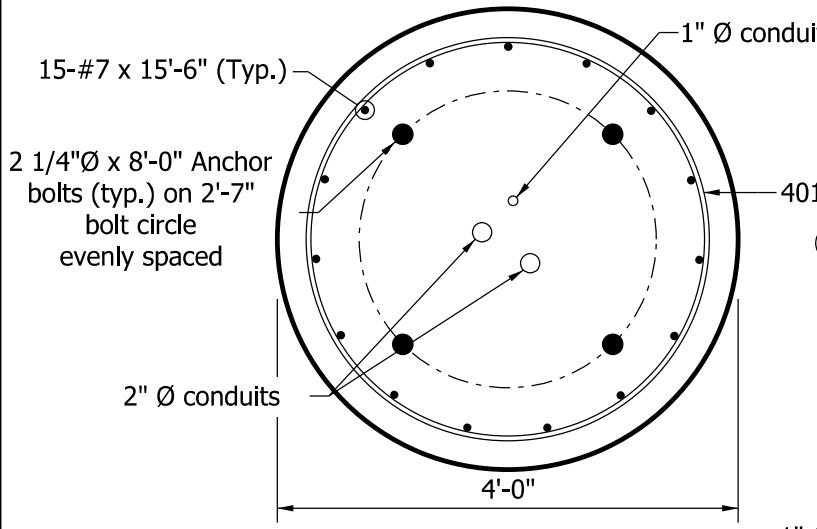

**SECTION I-I**

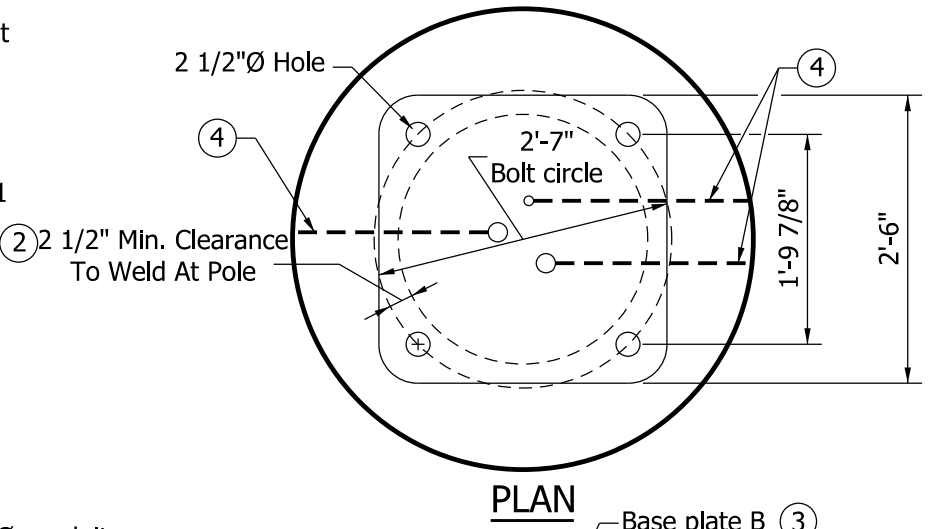

**PLAN**

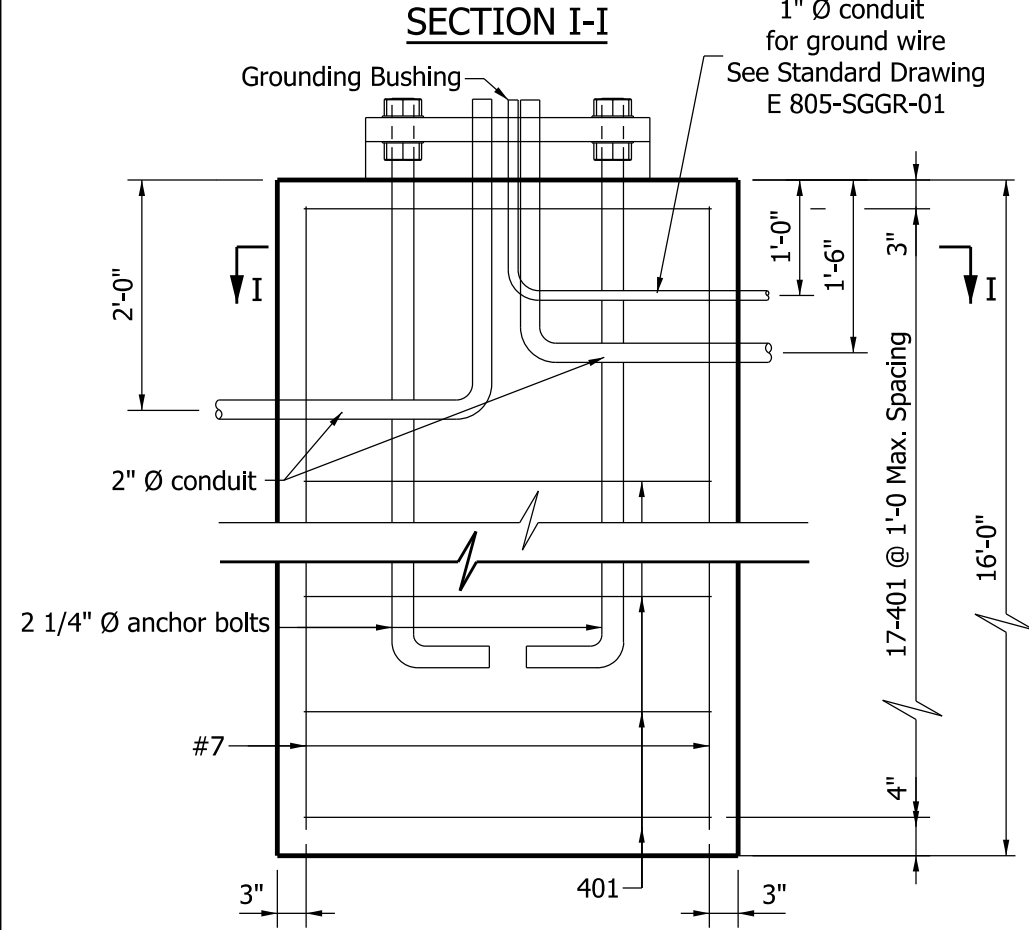

**SHAFT SECTION**

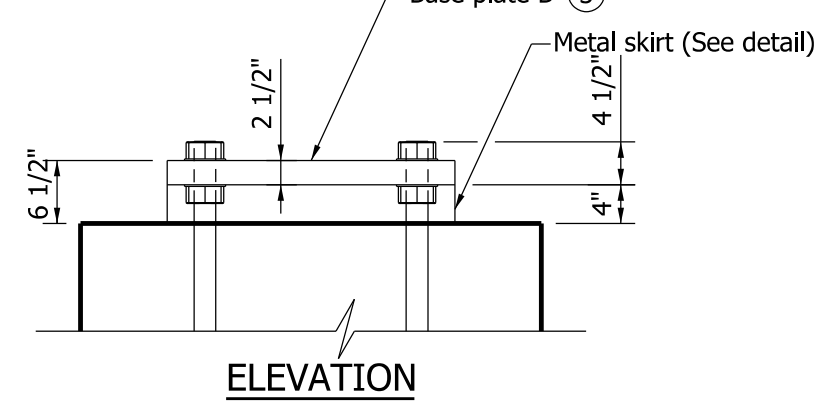

**ELEVATION**

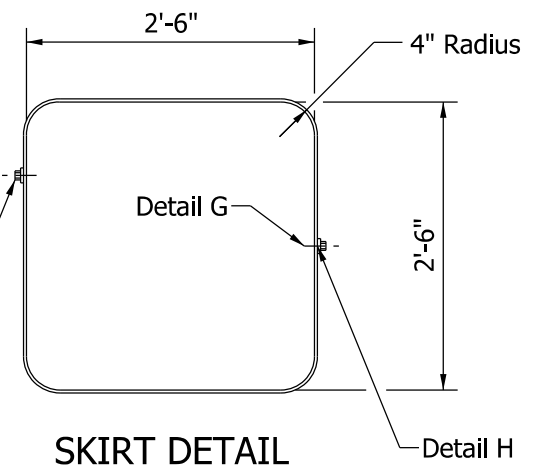

**SKIRT DETAIL**

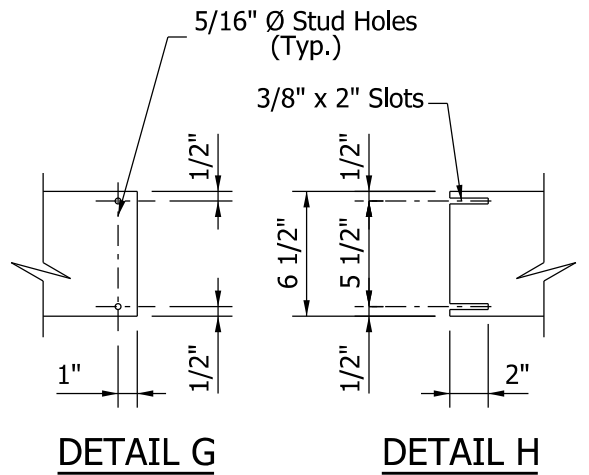

**DETAIL G**

**DETAIL H**

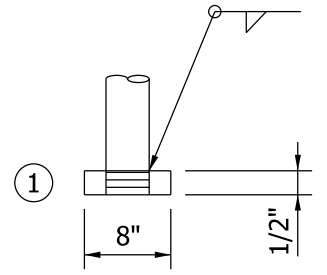

**1**

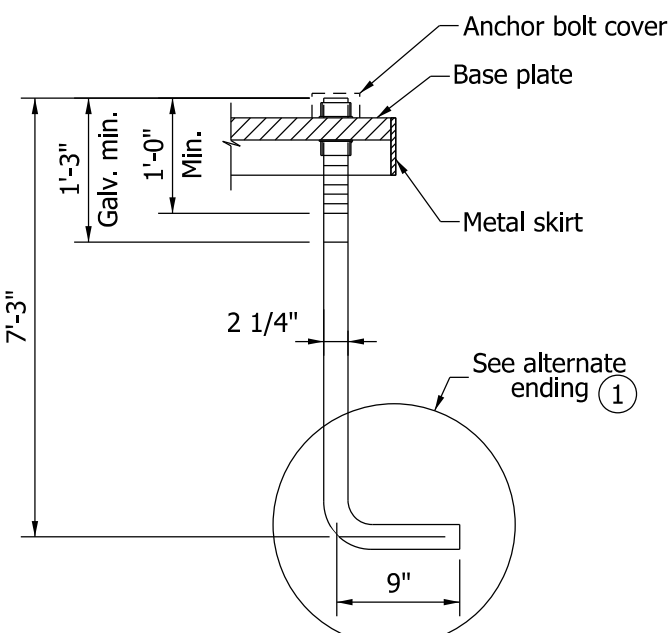

**ANCHOR BOLT B DETAIL**

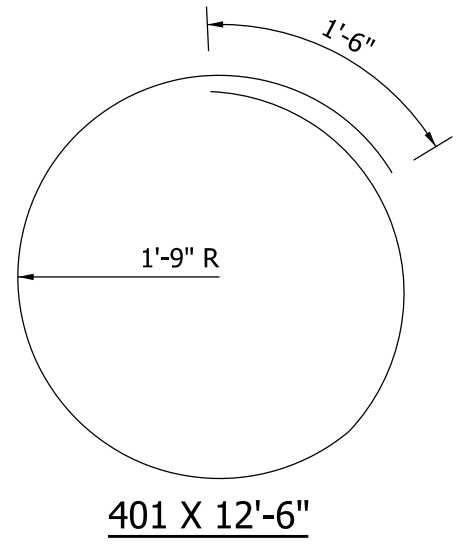

**401 X 12'-6"**

**NOTES:**

- ① Alternate 8" x 8" x 1/2" square plate tapped and welded to the anchor bolt may be substituted for bent anchor bolt.
- ② Bolt circle, b, shall allow clearance for the plate washer. Cutting or trimming the washer will not be allowed.
- ③ See Standard Drawing E 805-TSCS-04 for base plate B details.
- ④ A tooled line or other type of permanent marking shall be provided on the top of the foundation to indicate the direction of the conduits.

**BILL OF MATERIALS  
DRILLED SHAFT  
TYPE B**

REINFORCING BARS			
SIZE OR MARK	NUMBER OF BARS	LENGTH	WEIGHT (lbs.)
#7	15	15'-6"	
Total #7			475
401	17	12'-6"	
Total #4			142
Total Reinforcing Bars			617
CONCRETE			
Concrete, Class A			7.5 CYS

**INDIANA DEPARTMENT OF TRANSPORTATION**

**TRAFFIC SIGNAL CANTILEVER STRUCTURE  
DRILLED SHAFT FOUNDATION TYPE B  
FOR ARM OF GREATER THAN 35' TO 60'  
SEPTEMBER 2013**

**STANDARD DRAWING NO. E 805-TSCS-17**

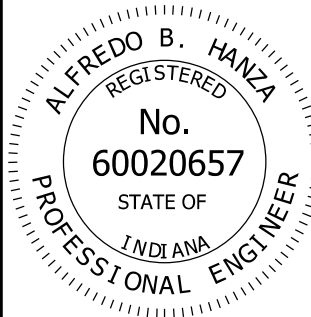

*/s/ Alfredo B. Hanza* 02/05/13  
DESIGN STANDARDS ENGINEER DATE

*/s/ Mark A. Miller* 03/27/13  
CHIEF ENGINEER DATE

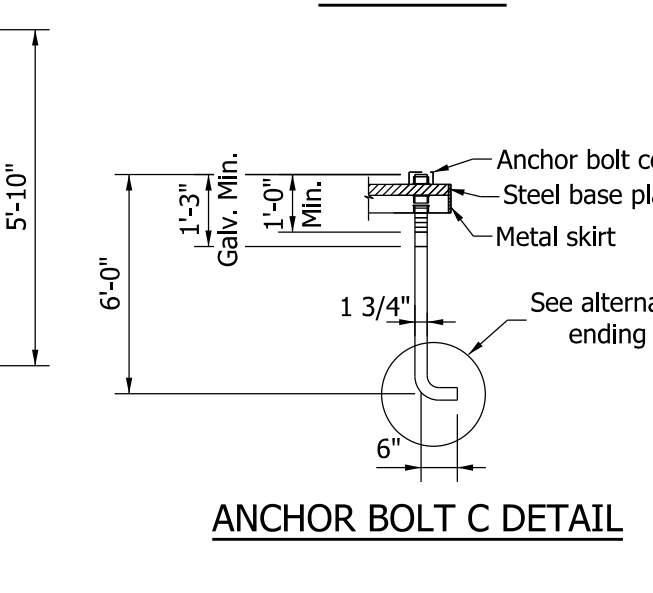
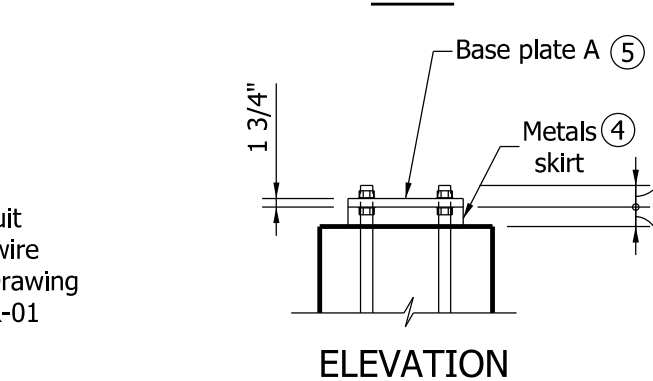
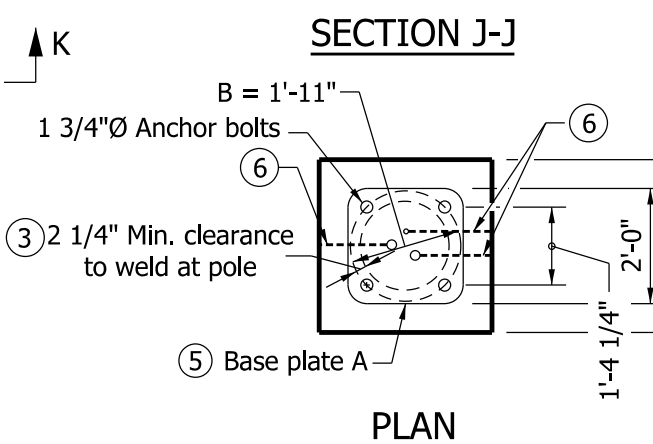
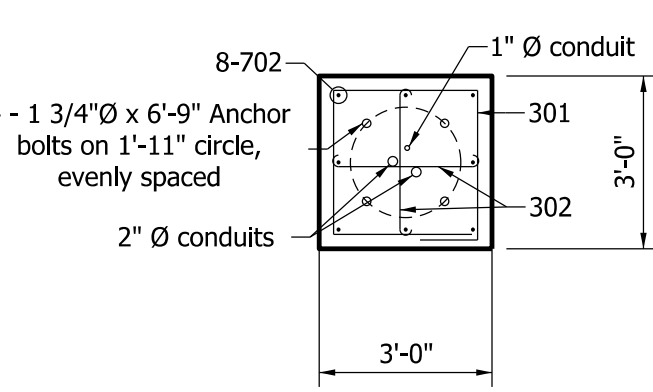
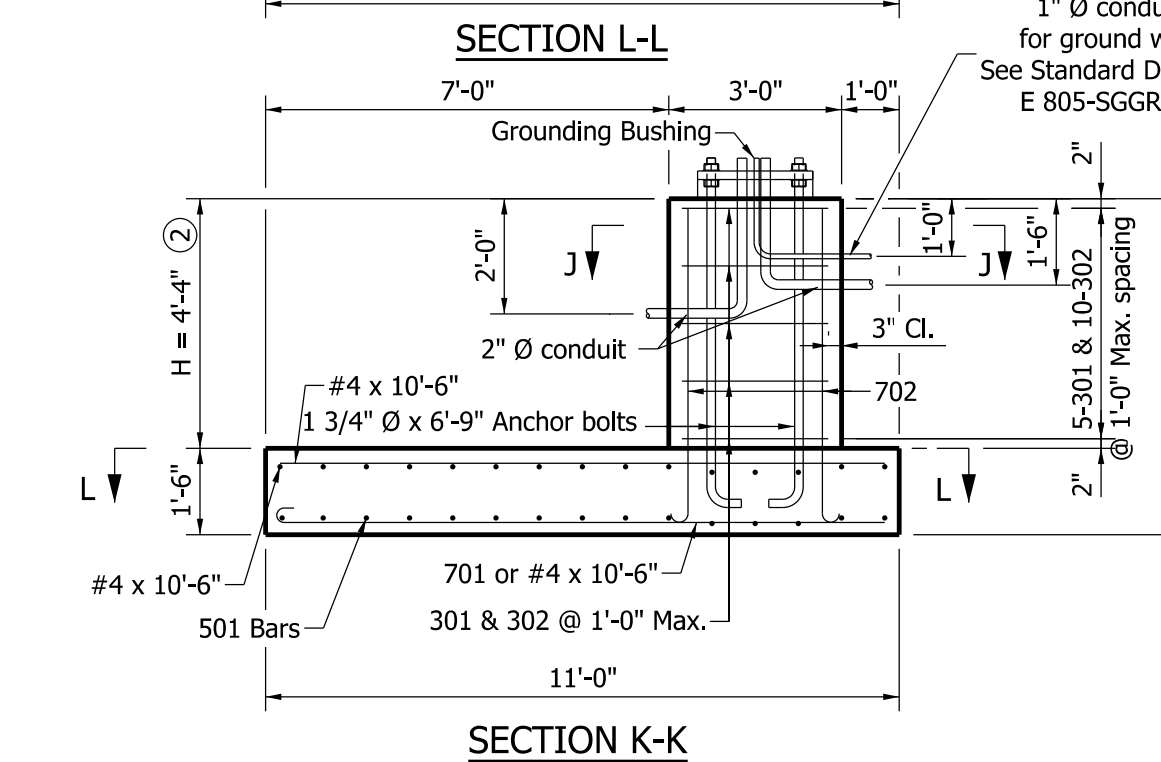
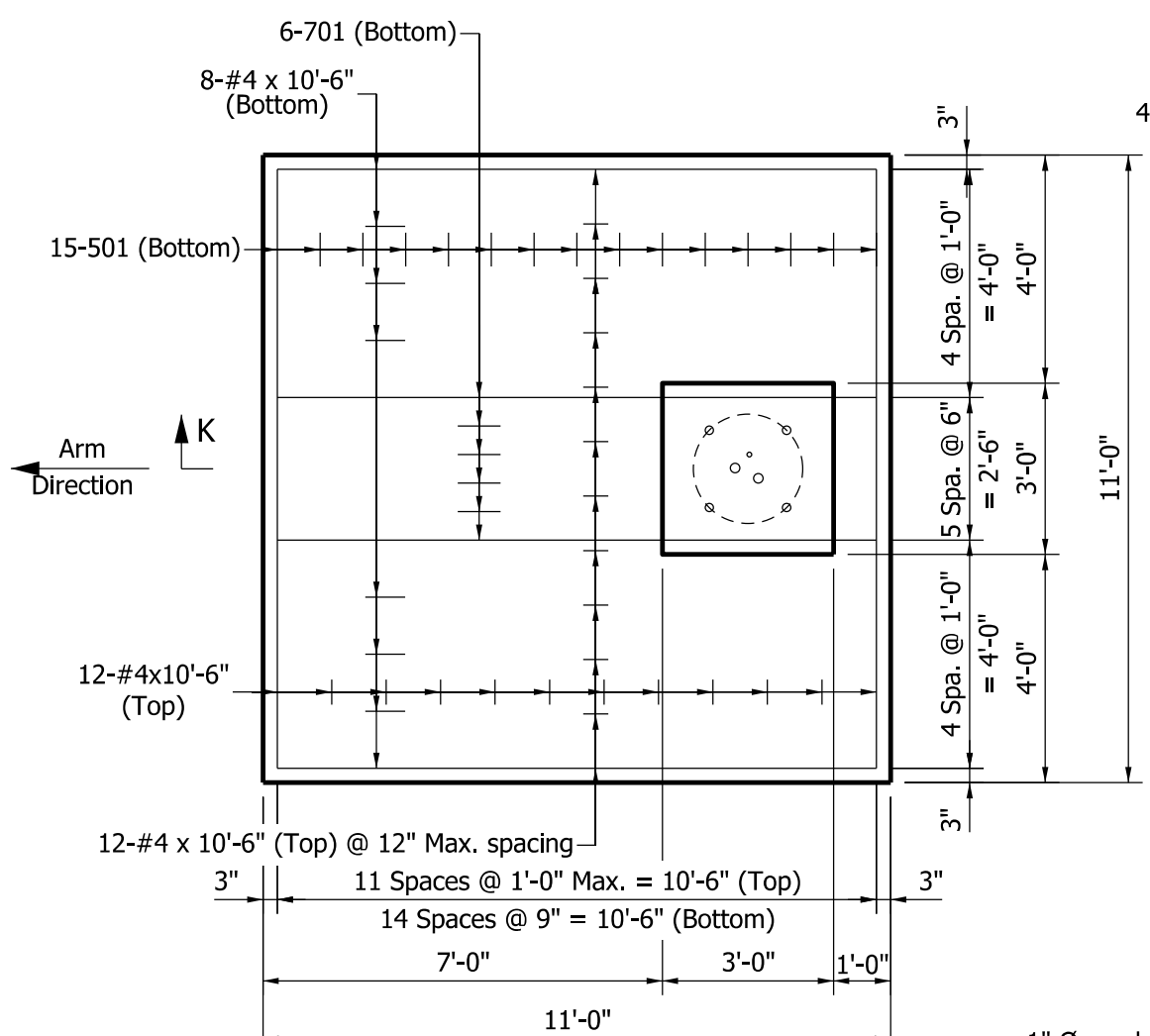

- NOTES:**
- ① Alternate 6" x 6" x 1/2" square washer with hex nut welded to lower end may be substituted for the bend in the anchor bolt.
  - ② Minimum H required is 4 ft. soil cover over the entire footing area.
  - ③ Bolt circle, B, shall allow clearance for the plate washer. Cutting or trimming the washer will not be allowed.
  - ④ See Standard Drawing E 805-TSCS-16 for metal skirt details.
  - ⑤ See Standard Drawing E 805-TSCS-04 for base plate A details.
  - ⑥ A tooled line or other type of permanent marking shall be provided on the top of the foundation to indicate the direction of the conduits.

BILL OF MATERIALS SPREAD FOOTING TYPE C			
REINFORCING BARS			
SIZE OR MARK	NUMBER OF BARS	LENGTH	WEIGHT (lbs.)
701	6	11'-4"	
702	8	6'-0"	
Total #7			237
501	15	11'-8"	
Total #5			183
#4	32	10'-6"	
Total #4			224
301	5	11'-0"	
302	10	3'-4"	
Total #3			33
Total Reinforcing Bars			677
CONCRETE			
Concrete, Class A			8.2 CYS

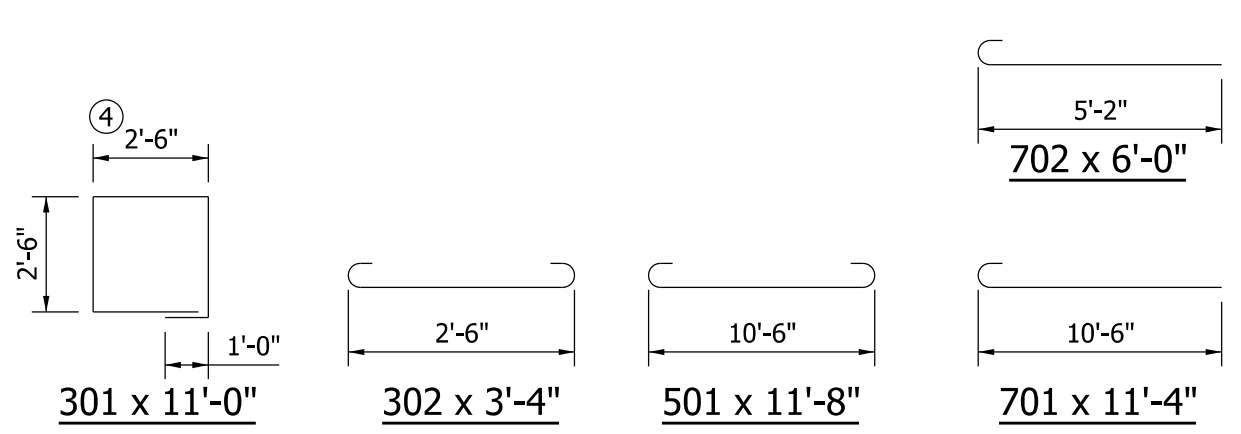

**INDIANA DEPARTMENT OF TRANSPORTATION**

**TRAFFIC SIGNAL CANTILEVER STRUCTURE  
SPREAD FOOTING FOUNDATION TYPE C  
FOR ARM OF 35' OR LESS**

**SEPTEMBER 2013**

---

**STANDARD DRAWING NO. E 805-TSCS-18**

	<p>/s/ <i>Alfredo B. Hanza</i>      02/05/13</p> <p>DESIGN STANDARDS ENGINEER      DATE</p> <p>/s/ <i>Mark A. Miller</i>      03/27/13</p> <p>CHIEF ENGINEER      DATE</p>
--	--

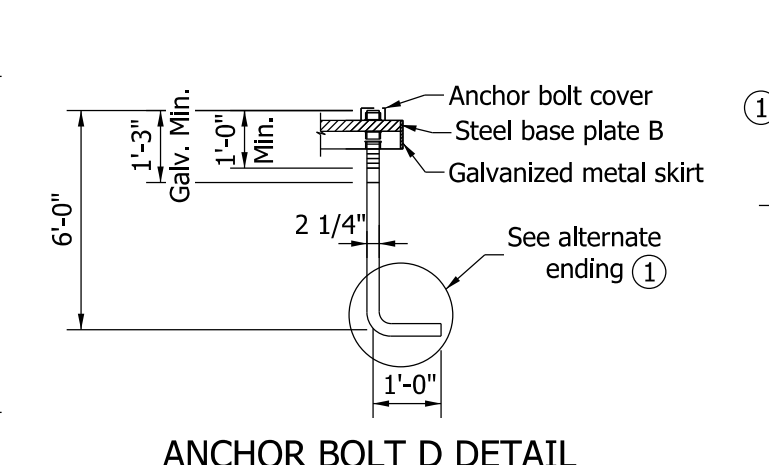
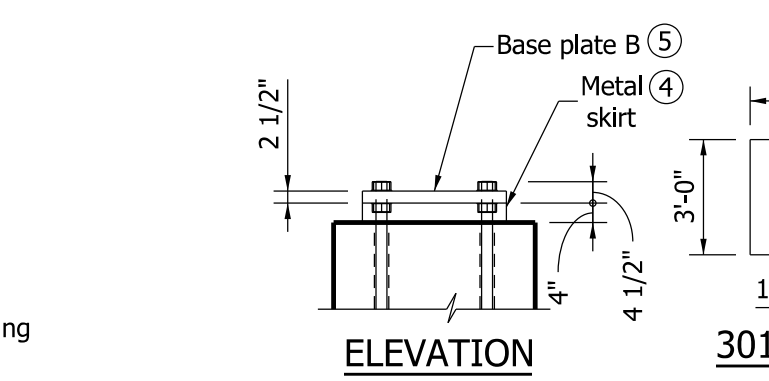
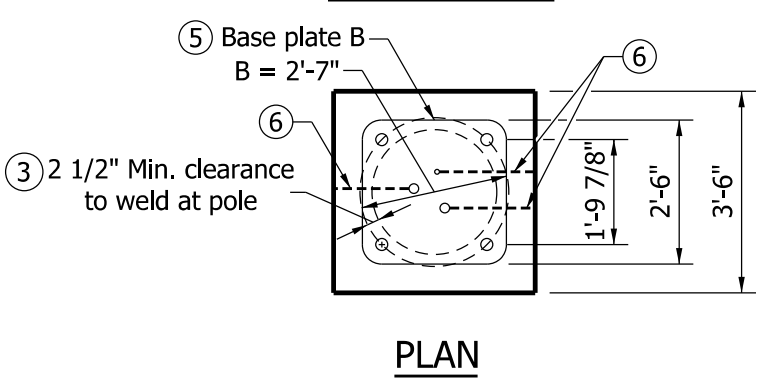
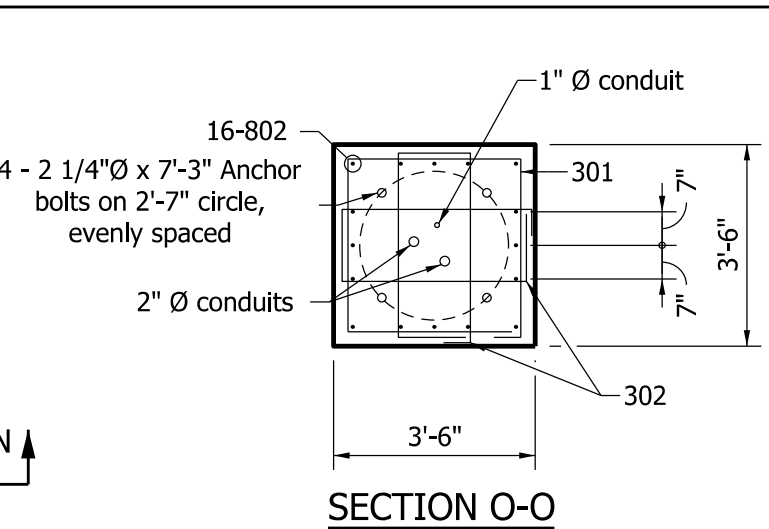
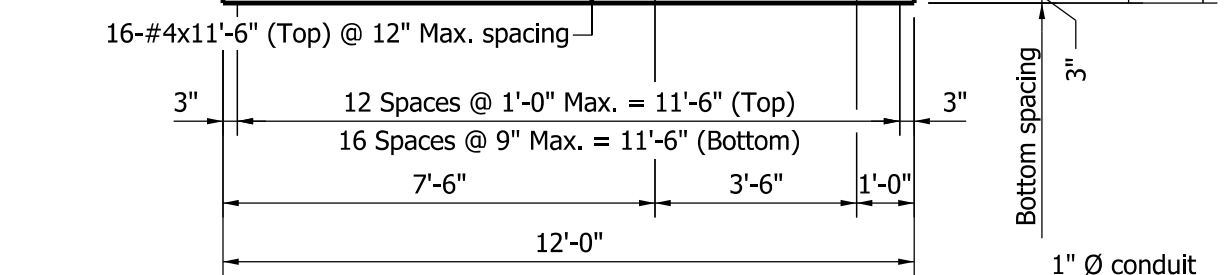
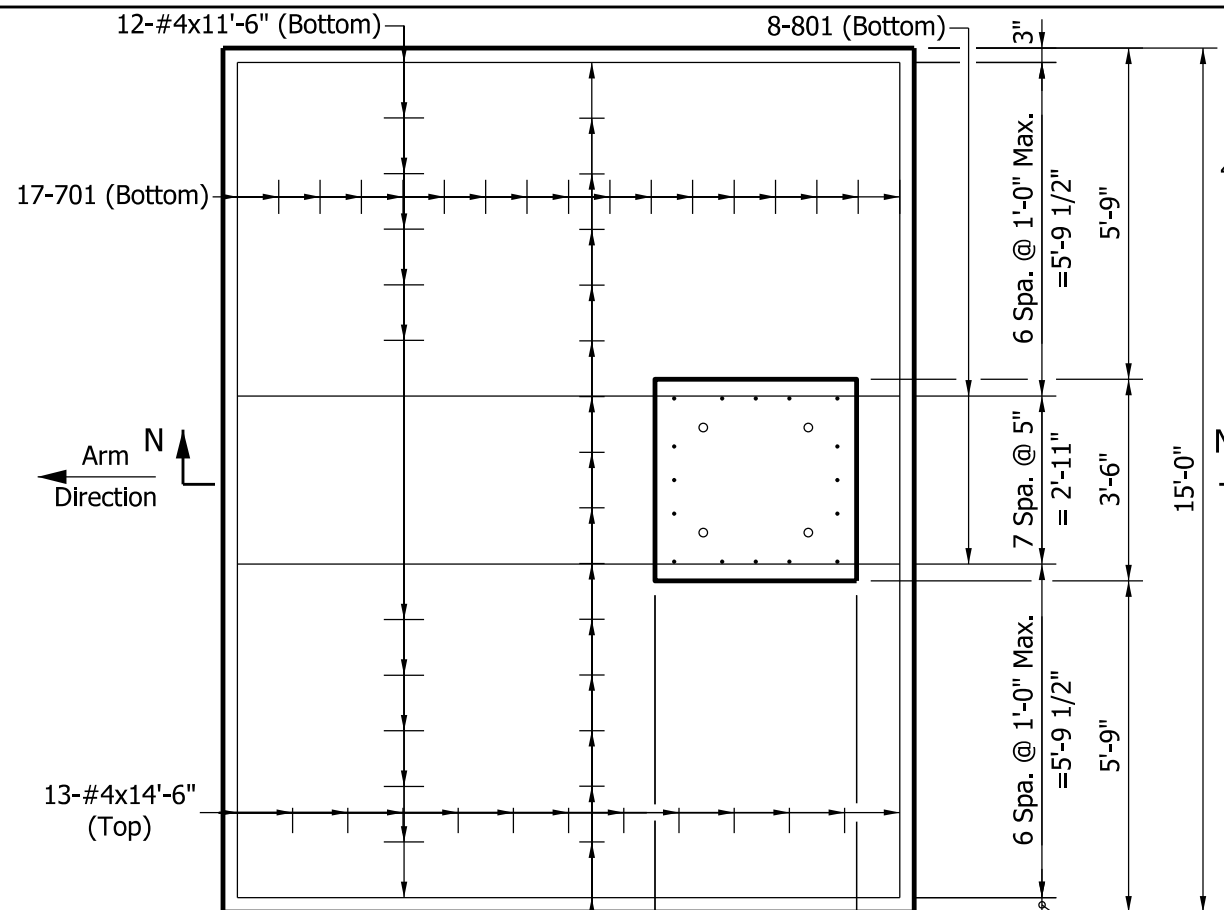

- NOTES:**
- ① Alternate 8" x 8" x 1/2" square plate tapped and welded to anchor bolt may be substituted for the bent anchor bolt.
  - ② Minimum H required is 4 ft. soil cover over the entire footing area.
  - ③ Bolt circle, B, shall allow clearance for the plate washer. Cutting or trimming the washer will not be allowed.
  - ④ See Standard Drawing E 805-TSCS-17 for metal skirt details.
  - ⑤ See Standard Drawing E 805-TSCS-04 for base plate B details.
  - ⑥ A tooled line or other type of permanent marking shall be provided on the top of the foundation to indicate the direction of the conduits.

BILL OF MATERIALS SPREAD FOOTING TYPE D			
REINFORCING BARS			
SIZE OR MARK	NUMBER OF BARS	LENGTH	WEIGHT (lbs.)
801	8	11'-5"	
802	16	6'-1"	
Total #8			504
701	17	16'-2"	
Total #7			562
#4	13	14'-6"	
#4	28	11'-6"	
Total #4			341
301	5	13'-0"	
302	10	9'-8"	
Total #3			61
Total Reinforcing Bars			1468
CONCRETE			
Concrete, Class A			12.0 CYS

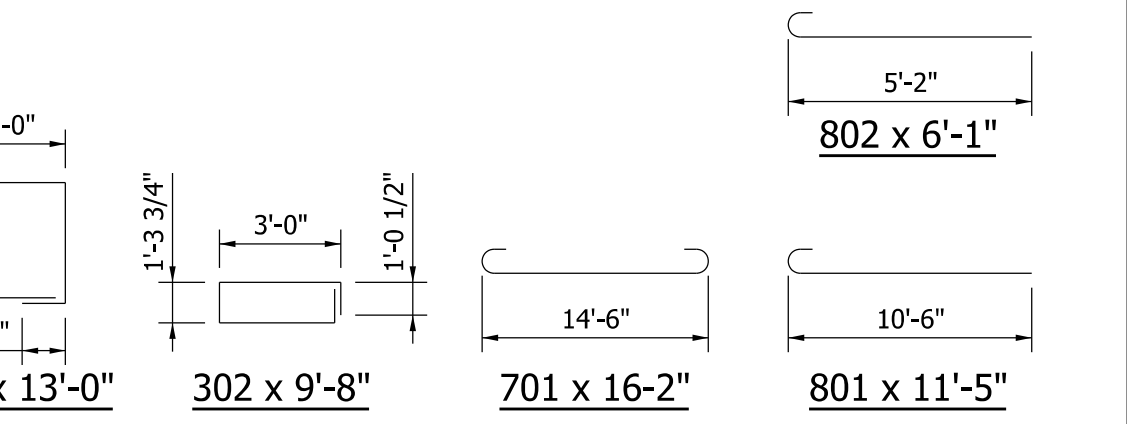

**INDIANA DEPARTMENT OF TRANSPORTATION**

**TRAFFIC SIGNAL CANTILEVER STRUCTURE  
SPREAD FOOTING FOUNDATION TYPE D  
FOR ARM OF GREATER THAN 35' TO 60'**

**SEPTEMBER 2013**

---

STANDARD DRAWING NO. **E 805-TSCS-19**

	/s/ <i>Alfredo B. Hanza</i>	02/05/13
	DESIGN STANDARDS ENGINEER	DATE
	/s/ <i>Mark A. Miller</i>	03/27/13
	CHIEF ENGINEER	DATE